

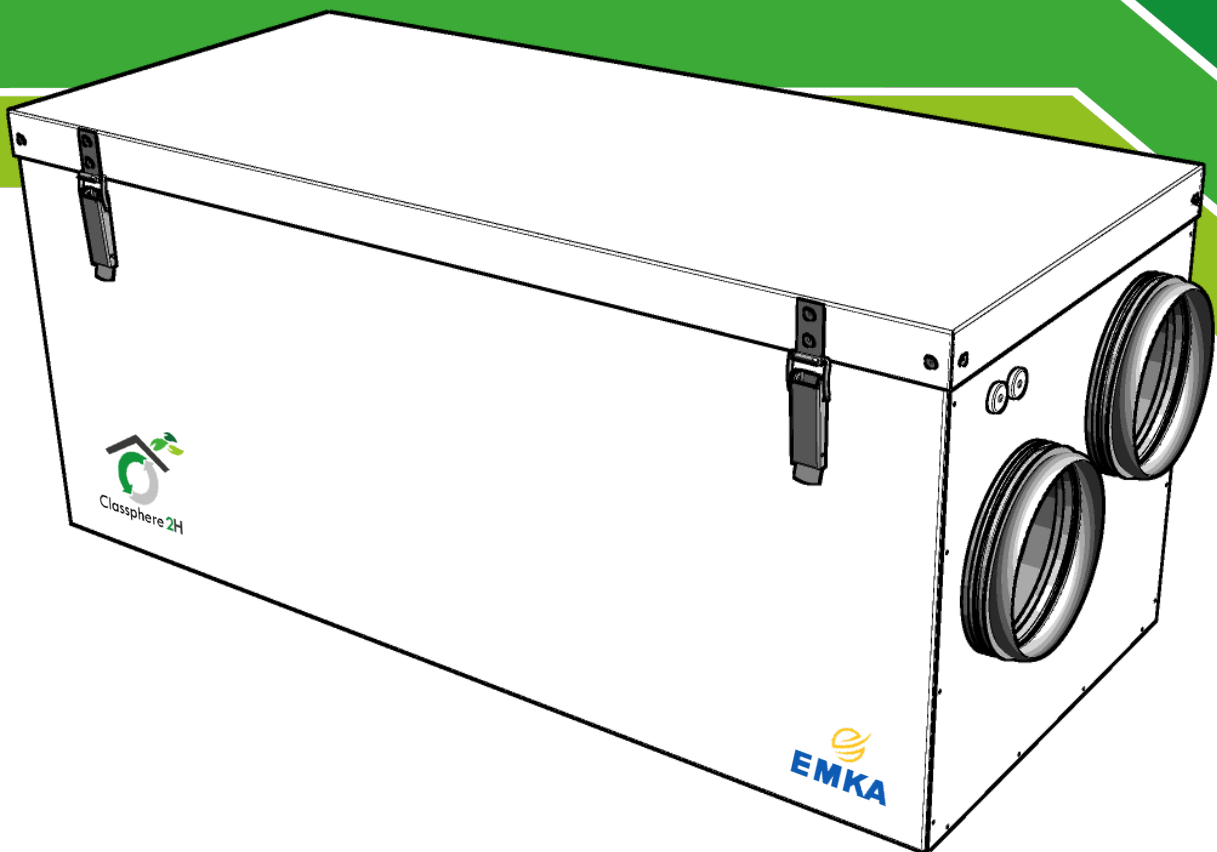

Classphere® 2H



INSTALLATION & MAINTENANCE MANUAL
Air handling unit and automatic control



Content

Safety instructions 4

Installation manual

- 1. Symbols used 6
 - 1.1. Unit Identification tag 6
- 2. Description 7
 - 2.1. General specifications 7
 - 2.2. System description 8
 - 2.3. Unit technical description 9
 - 2.4. Sizes / Physical measures 10
- 3. Reception and unpacking 11
 - 3.1. Unpacking 11
 - 3.2. Packaging content 12
- 4. Unit installation 13
 - 4.1. Installers 13
 - 4.2. Electrician 13
 - 4.3. Unit location 14
 - 4.4. Floor mounting 14
 - 4.5. Duct connection 15
 - 4.6. Door handling 16
- 5. The control panel 17
 - 5.1. Description 17
 - 5.2. Cable installation 17
 - 5.3. Control panel installation 18
 - 5.4. Unit calibration 19

Maintenance manual

- 6. Unit maintenance 20
 - 6.1. Thermostat reset 20
 - 6.2. Changing the filters 21
 - 6.3. Cleaning the fans 22
 - 6.4. Cleaning the rotor 23
 - 6.5. Changing the brush strips 24
 - 6.6. External cleaning 24
- 7. Overview MK control panel 25
 - 7.1. Description 25
- 8. Overview of Software 26
 - 8.1. Description 26
 - 8.2. Control panel navigation 27
 - 8.3. Standby mode 27
- 9. Start Menu 27

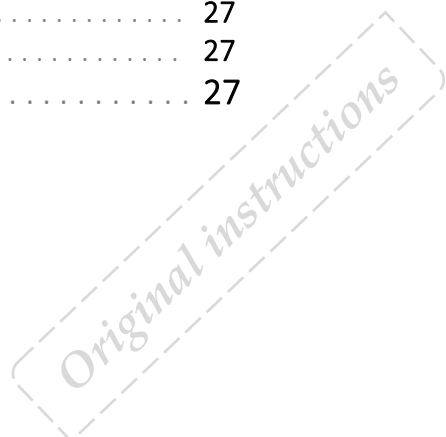

Content

10. Main Menu	28
10.1. Measurements	28
10.2. Settings	28
10.3. Date and Time	30
10.4. Language	30
10.5. System Info	30
11. Advanced User Menu	31
11.1. CO2 Settings	31
11.2. Calibration Test	31
11.3. Ventilation	31
11.4. Alarms	32
11.5. Menu Tree	33
12. Cleaning and maintenance	34
13. Troubleshooting	34
EC Declaration of conformity	36

 **Important Safety Instructions:**

It is the installer's responsibility to carry out a full safety and function assessment of the appliance.

To reduce the risk of fire, electric shock or injury, read all the safety instructions and warning before using the unit.

- Positioning must accord with individual countries' electrical safety legislation. Please check which rules apply in your country.
- This unit is only designed for ventilation air in homes and commercial buildings.
- It must not be used to extract combustible or flammable gases.
- The outer space of the ventilation inlet must be large enough to allow the inscription of a circle greater than 3 meters.
- Ventilation inlets in contact with the outside must be arranged in such a way as to prevent the entry of rainwater or be equipped with suitable elements for the same purpose.
- Ventilation outlets must be separated by at least 3 meters from any ventilation inlet element and from spaces where there may be people on a regular basis.
- The unit must be installed with an earth leakage breaker. All electrical connections must be carried out by qualified electricians.
- If the power lead is damaged, it must be replaced by the manufacturer in order to avoid a hazard. The manufacturer's service agent or a similarly qualified person.
- Remove the power plug before commencing any service and maintenance work.
- The remote control cable must be at least 30 cm from any building power cables.
- Before opening the door, switch off or unplug the unit.
- The unit contains heating elements that must not be touched when they are hot.
- The door is heavy. Be careful when removing it.
- Do not use water to clean the unit.
- The control panel must be connected to the unit before the unit is plugged to the power.
- The unit must not be operated without the filters being in place.
- Children of less than 8 years shall only switch on/off the appliance provided that it has been placed or installed in its intended normal operating position and they have been given supervision or instruction concerning use of the appliance in a safe way and understand the hazards involved. Children of less than 8 years shall not plug in, regulate and clean the appliance or perform user maintenance.

Note that the product is not intended for use by children.

 **Important Safety Instructions:**

- Children shall not play with the appliance, could be injured.
- Some parts of this product can become very hot and cause burns. Particular attention has to be given where children and vulnerable people are present.
- Children of less than 3 years should be kept away unless continuously supervised.
- When the door is removed, keep it away from children.
- Users are advised not to use the maximum flow for long periods of time, as the useful life of the unit may be impaired .; maintaining the constant flow recommended by the installer.

To maintain a good indoor climate, comply with regulations and avoid condensation damage, the unit must never be stopped apart from during service/maintenance or in connection with an accident.

If you need more information, help from technical support or original instructions in another language you can visit us on the website: **www.emkamf.es**

Our products are subject to continuous development and we therefore reserve the right to make changes.

We also disclaim liability for any printing errors that may occur.

1. Symbols used

These products have a number of symbols that are used to label the product itself and in the installation and user documentation.

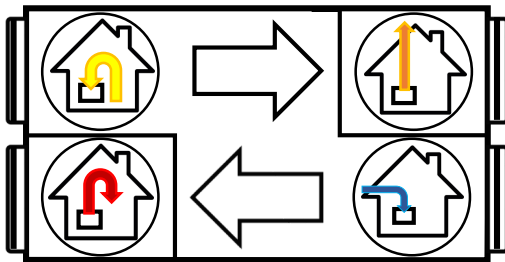
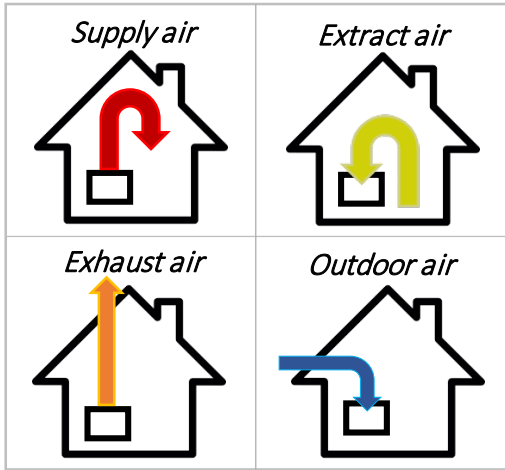

EXAMPLE OF NIPLE LOCATION



DANGER! ELECTRICITY



DANGER! DO NOT TOUCH

! WARNING

When a text bears this symbol, it means that personal injury or serious damage to the equipment may result if the instructions are not followed.

! CAUTION

When a text bears this symbol, damage to equipment or poor efficiency may be the consequence of not following the instructions.

1.1. Unit identification tag

TM CLASS MF
 Model: CLASSPHERE 2H
 Serial N°. HRU200H202136XXXXXX
 Manufacturer:
 CLASS MANUFACTURING, S.L.
 Urano, 2
 28936 Móstoles, Madrid.
 Spain
 Voltage: 230 V - 50/60 Hz
 Current: 6.8 A
 Power: 1550 W
 Fan power: 2 x 96 W
 Weight: 54 Kg
 Date: 08.09.2021

EN 60335-2-30
 EN 60335-2-80

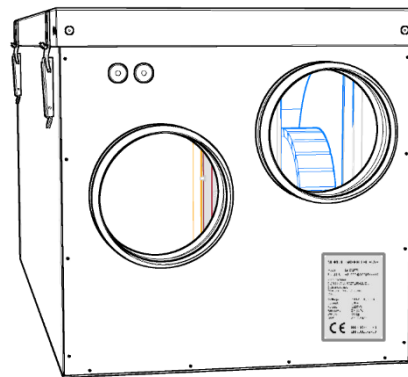

TRADE BRAND: Manufacturer's name

MODEL: Product name.

SERIAL N°
HRU200H: Model identification.
2021: Year of production.
36: Manufacturing week.
XXXXX: Product identification.

MANUFACTURER: Full name and address of the Manufacturer.

SPECIFICATIONS: Product features.

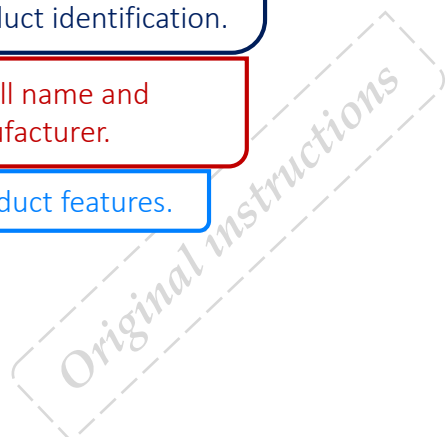

2. Description

2.1. General specifications

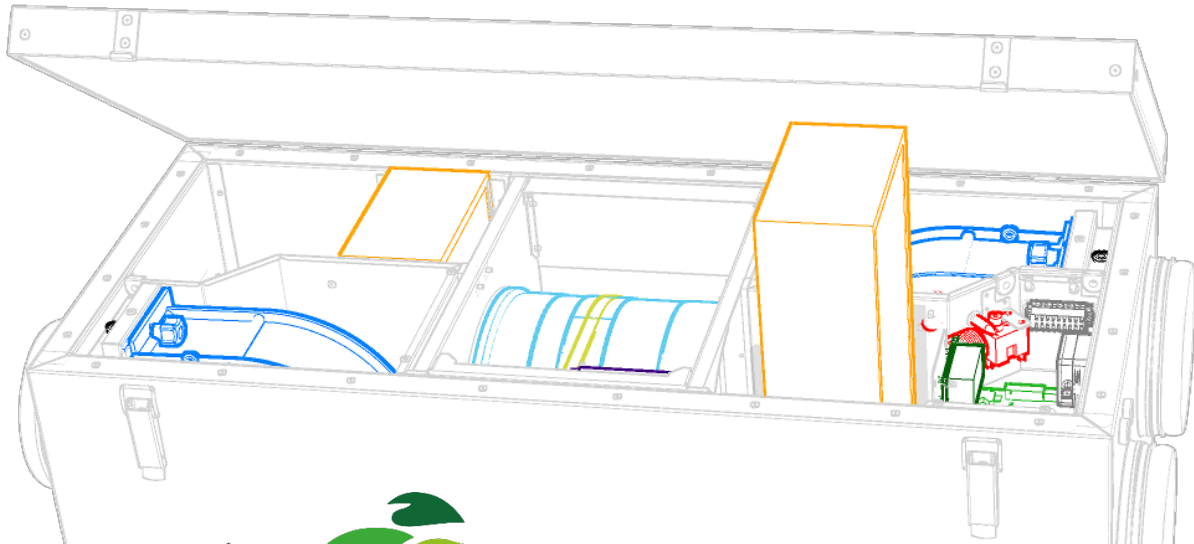

Classphere 2H

Rated airflow: 290 m³/h.
 Thermal efficiency: 82 %
 Sound power: 46 dB

- 1 CO₂ sensor (Ppm).
- 1 Relative humidity sensor (%).
- 4 Temperature sensors (°C).
- 2 Differential pressure sensors (Pa).
- 2 Air filters (F7).
- 1 Thermostat (60°).
- 1 Thermostat (50°).

Characteristics

Rated voltage	230 V / 50-60 Hz
Fuse	6,3 mA
Total rated current	6,8 A
Total rated power	1550 W
Rated voltage heating	230 V
Rated power heating	1400 W
Rated voltage, fan	200-240 V / 50-60 Hz
Rated current, fan	0,80 A
Rated power, fan	96 W x 2
Fan speed (max. rpm)	3374 rpm
Fan motor control	0-10 V
Fan type	B wheel
Rated voltage, rotor	24 VDC
Rated current, rotor	0,6 A
Rated power, rotor	14,4 W
Motor speed, rotor	0-300 rpm
Motor type, rotor	Brushless DC
Filter type	F7
Filter dimensoins	167 x 345 x 98 mm
Weight	54 Kg
Duct connection	Ø 160 mm
Height	427 mm
Width	433 mm
Depth	1040 mm

2. 2. System description

- | | |
|---|--------------------------------------|
| <i>J11</i> Overheating switch | <i>Fn1</i> Supply air fan |
| <i>J12</i> Overheating switch | <i>Fn2</i> Exhaust air fan |
| <i>J13</i> Exhaust air temperature sensor | <i>Tt</i> Heating element |
| <i>J14</i> Outdoor air temperature sensor | <i>CO2</i> Indoor air quality sensor |
| <i>J15</i> Supply air temperature sensor | <i>RH</i> Relative humidity sensor |
| <i>J16</i> Extract air temperature sensor | <i>X50</i> Airflow sensor |
| <i>FL1</i> Outdoor air filter | <i>X51</i> Airflow sensor |
| <i>FL2</i> Extract air filter | <i>HR</i> Rotary heat exchanger |

- Theoretical drawing of the positioning of the components in the unit.

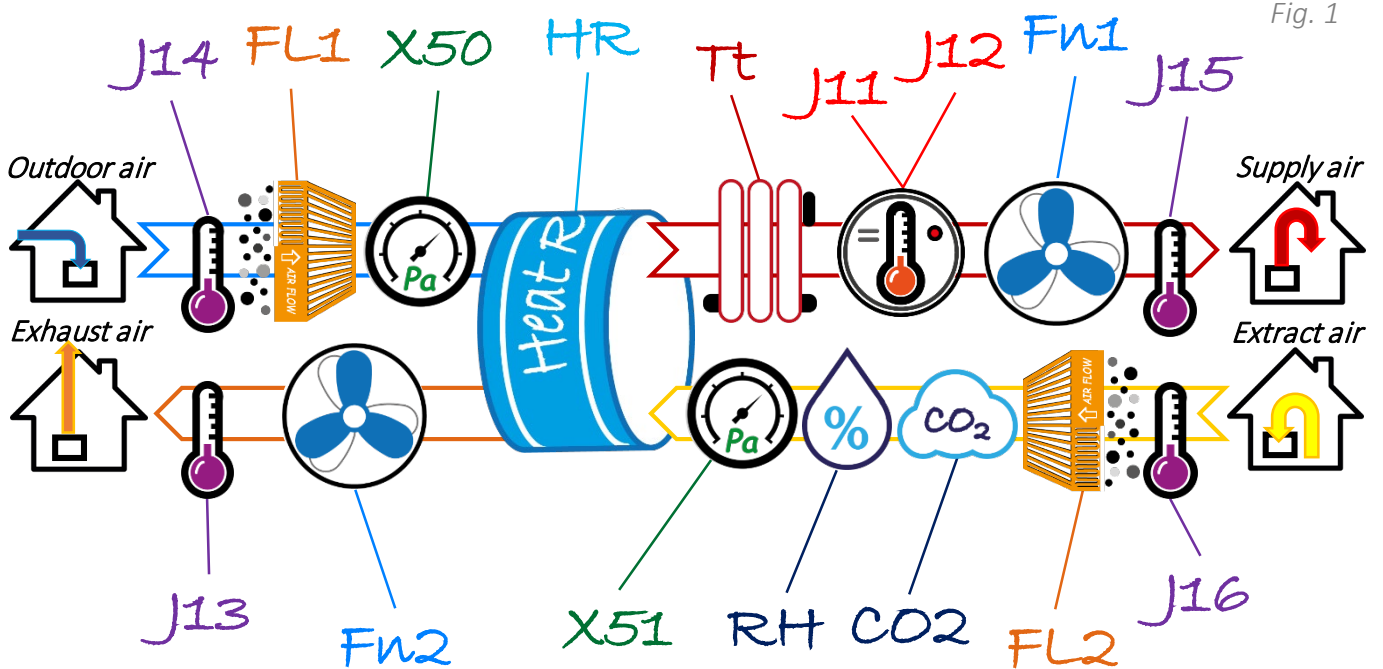

Fig. 1

- Description of air inlets and outlets.

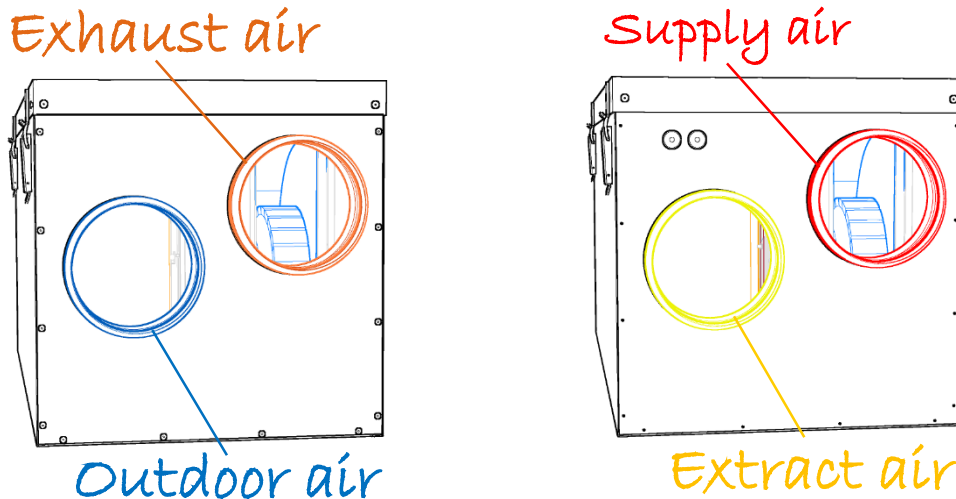
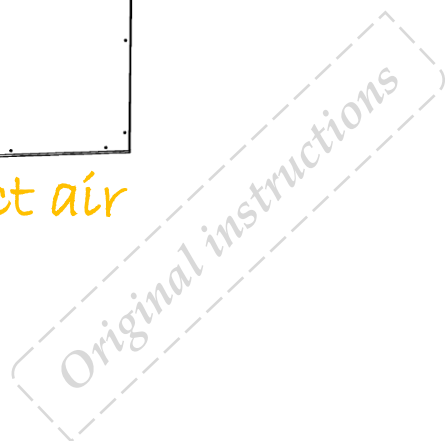

Fig. 2



2.3. Unit Technical description

- | | |
|---|--|
| 1 Bulb thermostat | 11 Resistor 1400W |
| 2 Thermostat Bi-Metal | 12 CO2 sensor |
| 3 NTC sensor (Exhaust) | 13 Relative humidity sensor |
| 4 NTC sensor (Outdoor) | 14 Differential pressure sensor (Supply) |
| 5 NTC sensor (Supply) | 15 Differential pressure sensor (Extract) |
| 6 NTC sensor (Extract) | 16 Rotary heat exchanger (Sorption, Ø250mm) |
| 7 Air filter F7 (Outdoor) | 17 Transmission belt |
| 8 Air filter F7 (Extract) | 18 Rotor motor (DC - 24v) |
| 9 Centrifugal fan 96W (Supply) | 19 Control board (220v) |
| 10 Centrifugal fan 96W (Exhaust) | 20 Power supply 24v. |

- The isolation on the walls of the unit is 30mm thick porex.

Fig. 3

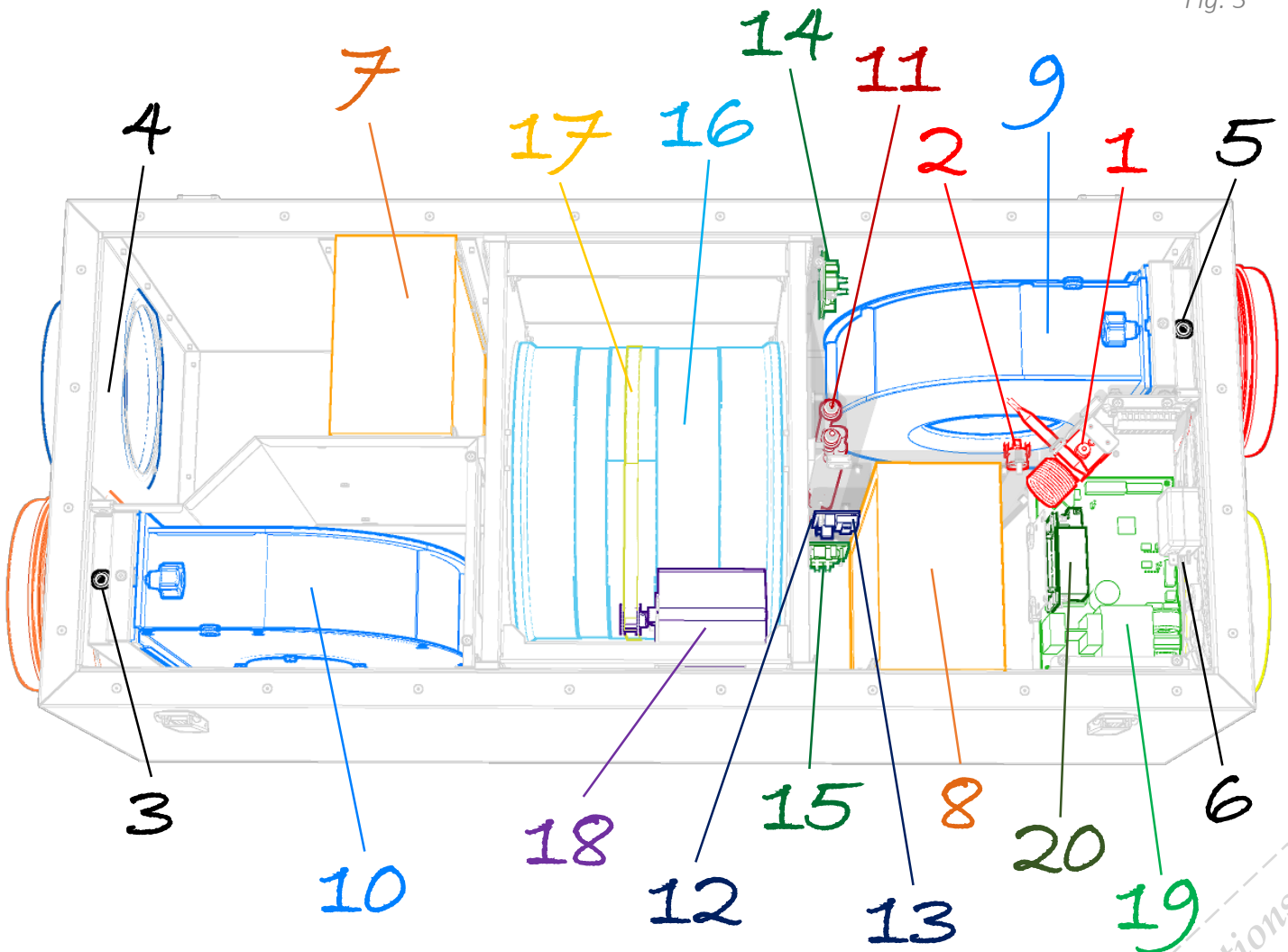

Original instructions

2. 4. Sizes / physical measures

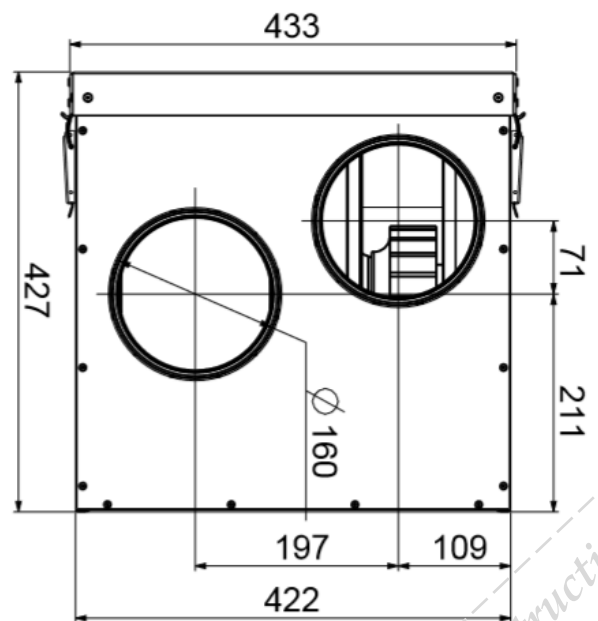
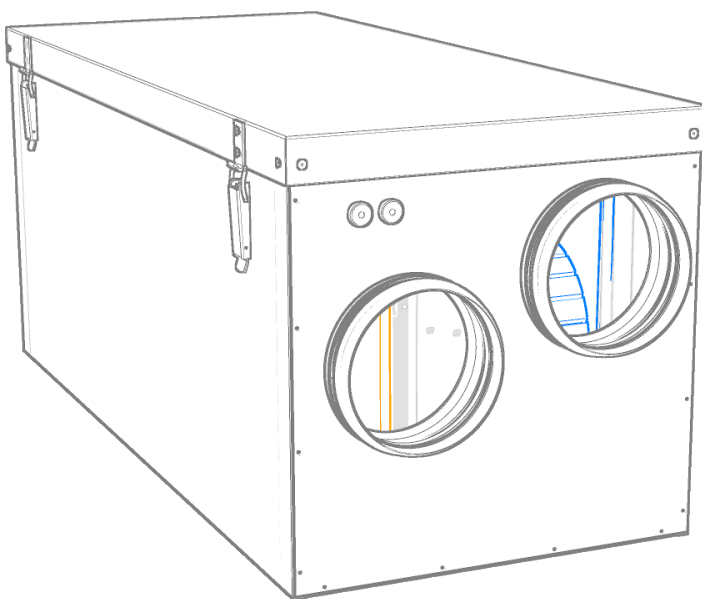
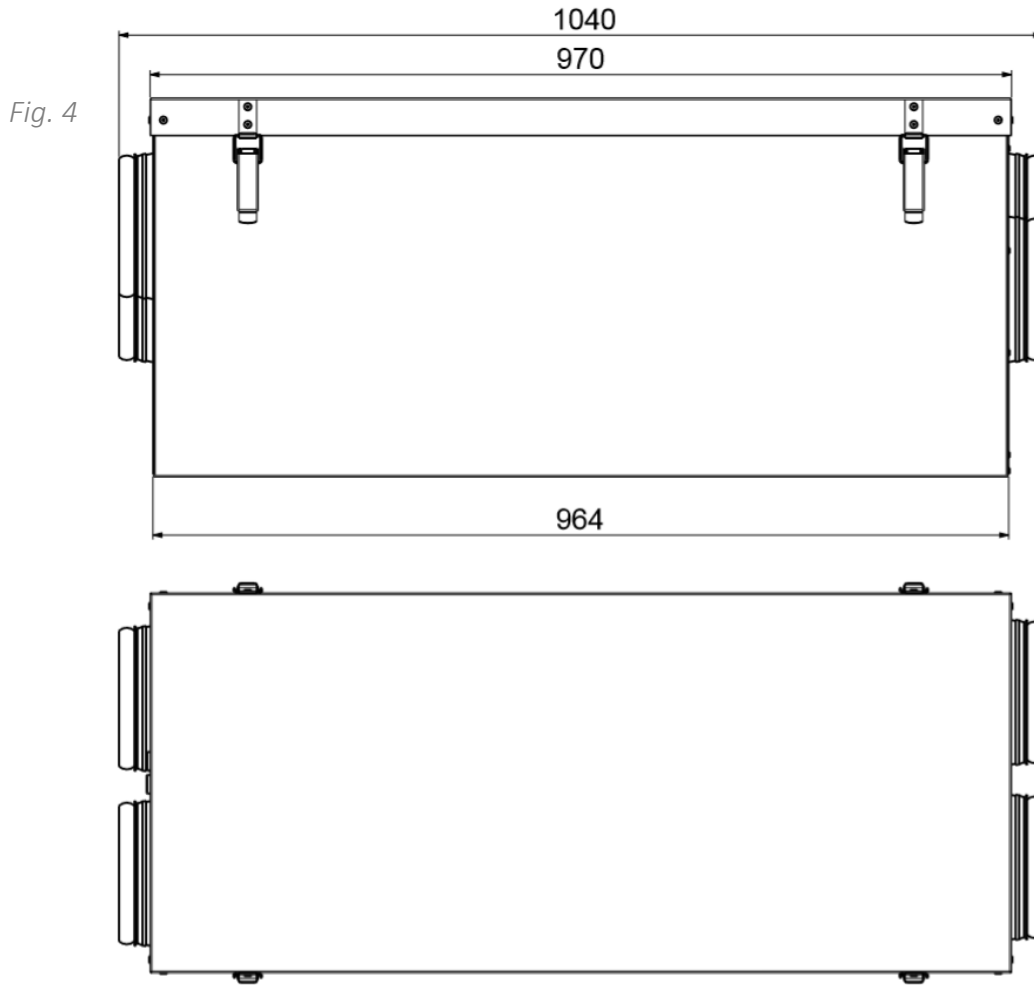

3. Reception and unpacking

3.1. Unpacking

- Check the perfect condition of the product when unpacking it, because any defect of origin that the unit presents, is covered by the warranty.
- Check that the specifications on the unit label match your needs.
- The packaging of this unit has been designed to withstand normal transport conditions, this product should not be transported out of its original packaging, as it could deform or deteriorate.
- The product must be stored in its original packaging and in a dry place protected from dirt until its final installation.
- Do not accept a unit without its original packaging or showing signs of tampering.
- It is recommended to avoid knocks or falls and to place excessive weights on the packaging.
- This product is heavy, use appropriate lifting elements to avoid damaging people and the product itself.

CAUTION
This product is heavy, never lift the unit without the help of another person.

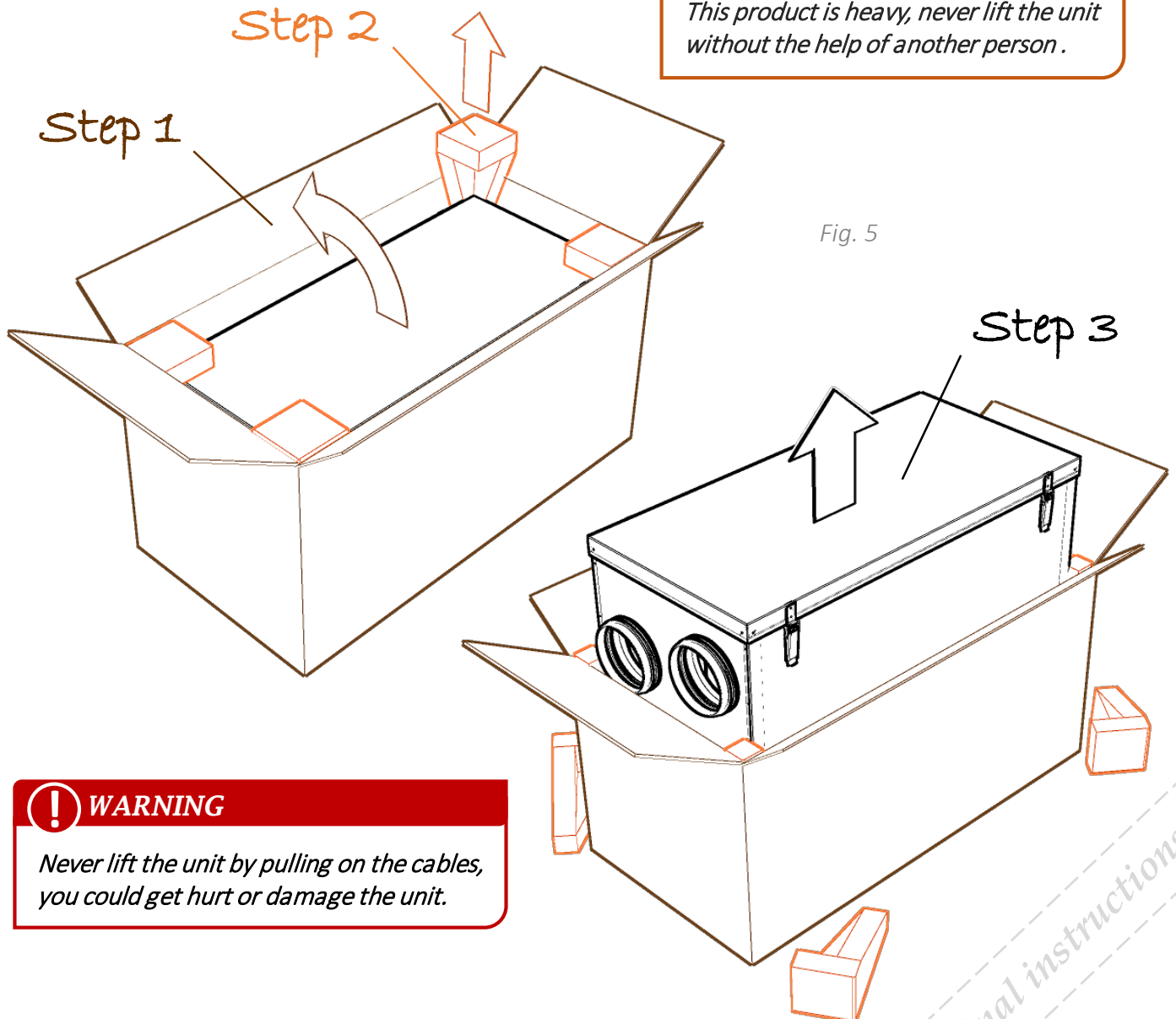

WARNING
Never lift the unit by pulling on the cables, you could get hurt or damage the unit.

Original instructions

3.2. Packaging content

Into the packaging together to the unit , is included:

- Control panel
- Installation and maintenance instructions
- User instructions

The control panel is located in a box inside the unit's packaging.

The control panel cord and the power cable are connected to the unit, not pulling the cables could damage the unit.



Fig. 6

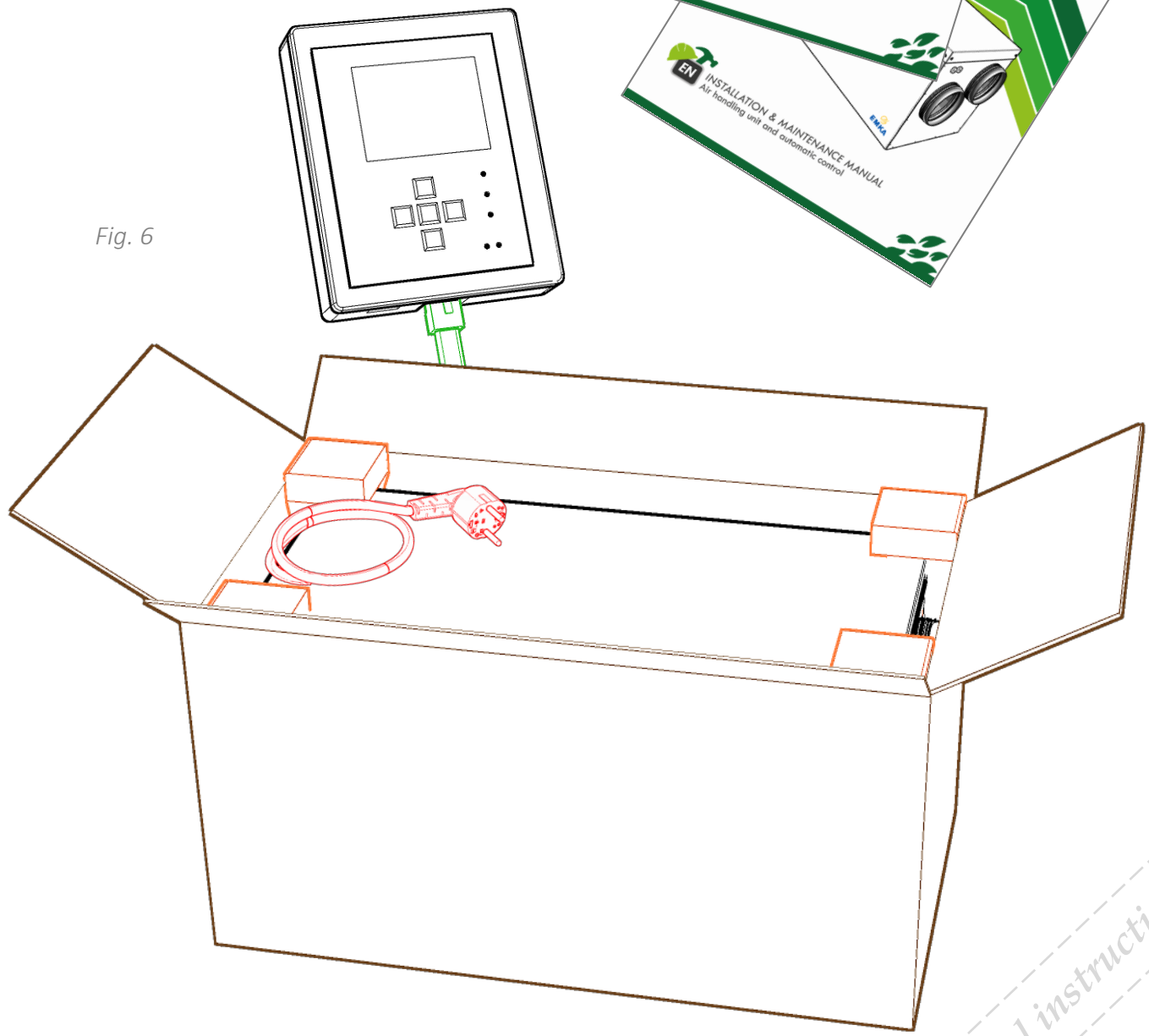

Original instructions

4. Unit installation

4.1. Installers

Door gaps

Make sure the air moves freely to every room.

Fireplace

If a fireplace is used, sufficient air must be ensured.

Location in the building

Location of the unit on an internal Wall requires insulation of the Wall, cut-off studs on boards and double plasterboard, or a Wall structure with a similar quality. Cabinet units should not be placed horizontally in wet rooms.

CAUTION

Positioning must accord with individual countries' electrical safety legislation. Please check which rules apply in your country.

Hanging a cabinet unit

Make sure the wall can stand the forces involved in hanging the device.

Access

The unit must have a good Access for service/maintenance. See pages 7 and 12 for more details

Fire requirements

Please consult your country's fire safety regulations.

WARNING

The installation instructions for the individual products must be followed

Duct covers

Plan and calculate the exact positioning of the unit and duct cover carefully before you start. See chapter 2. 4. for more information.

Placing sources of heat must be coordinated with extract air valves so the heat is not sucked straight out through a valve or door gap.

4.2. Electrician

Power supply

The units have 2.4m cable with plug which requires a single-phase earthed socket. Plug requirements: Type F, 220-240V, 16A.

It is important for the plug to be accessible for customer service when the unit is fully installed.

Wiring for the Control Panel.

ø20mm conduit for running the trailing cable for controlling the unit to be laid between the unit and an easily accessible place in the building. (e.g. Outside the bathroom). The control cable must be placed 30cm away from any power cables. The control cable must be 20m maximum to ensure a signal.

Control Panel

The Control Panel is designed for flush mounting over a single wall box or surface mounting on the wall.

WARNING

The unit must be installed with an earth leakage breaker. All electrical connections must be carried out by qualified electricians.

4.3. Unit location

The unit can be installed horizontally anywhere with enough space for maintenance. Also, the unit is symmetric so it can be placed according to the vents orientation.

The unit must be installed with sufficient space for service and maintenance such as changing the filters and cleaning the fans and the recovery system, minding enough area for the operator to open and handle all parts necessary from the device (see Fig. 7). The Control Panel cable must be also accessible.

These are the minimum requirements and only take service needs into account.

If the unit is put in a warm room where a lot of moisture is generated, condensation may form on the outside of the unit during periods with a low temperature outside.

4.4. Floor mounting

Positioning requirements

The unit is designed to be installed in boiler rooms, laundry rooms, stores or other suitable areas.

CAUTION

Positioning must accord with individual countries' electrical safety legislation. Please check which regulation applies in your country.

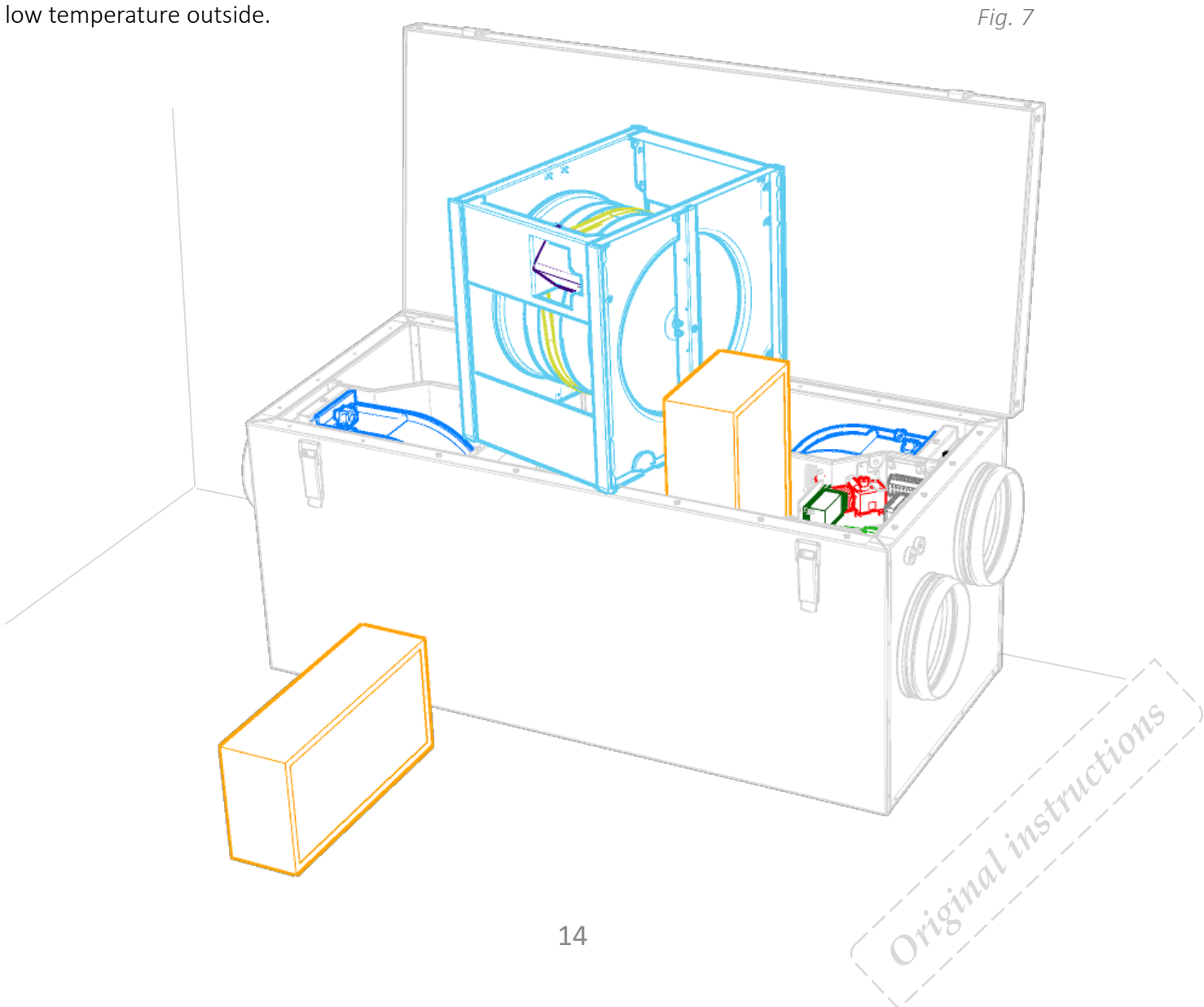

Fig. 7

4.5. Duct connection

Before start, make sure the ducts are properly arranged according to the ventilation system planning and match the unit's air takes.
(see fig. 8)

In order to avoid condensation during cold periods of time, it is important that all the ducts have proper insulation [3] all the way to the unit. Any ducts passing through a cold zone must also be properly insulated.

The ducts usually require min. 50mm insulation with a minimum capacity of $\lambda=0.035 \text{ W/m } ^\circ\text{C}$.

The planner is responsible for ensuring the necessary correct insulation is used according to the location and temperature requirements. Lay the outdoor air duct with a slight slope towards the outdoor air cap so any water that enters may drain out again.

The ducts should be soundproofed properly, especially above the ventilation unit.

Fig. 8

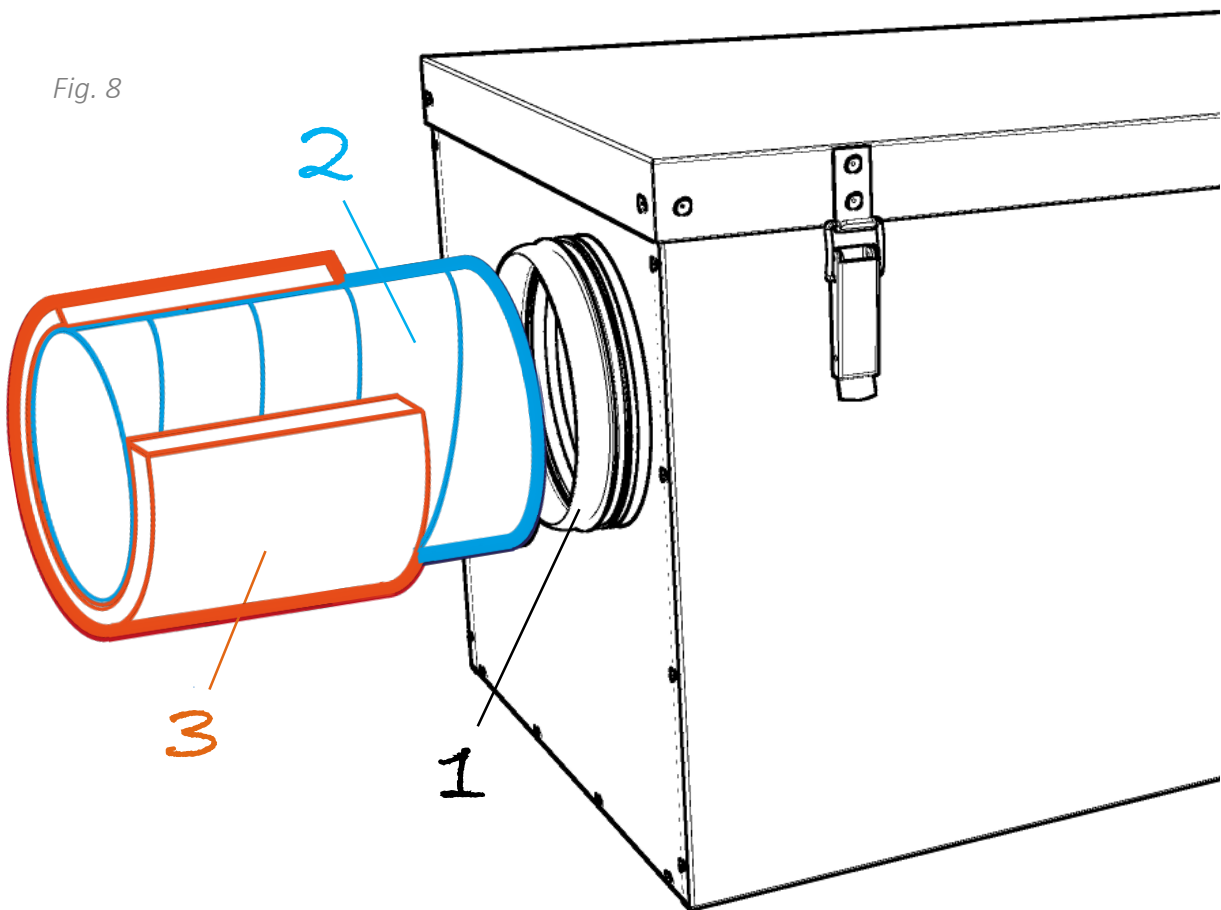

To install the spiral pipes [2], pull them down towards the nipple [1] until they reach the case of the unit, then cover the tube with the insulation. Make sure there is no gaps between the insulation and the unit in order to avoid condensation and possible formation of ice.

! CAUTION

Ventilation inlets in contact with the outside must be arranged in such a way as to prevent the entry of rainwater or be equipped with suitable elements for the same purpose.

4. 6. Door handling

The door is an essential element which keeps the device hermetic and insulates the sound from inside.

To open the door, it is only necessary to unhook all four latches of its position and remove the door. (see Fig. 9 and 10)

To close the door, all borders shall fit together correctly, once done, hook all four latches in position and then lower them for complete sealing.

CAUTION
The door is heavy. Be careful when removing it.

Fig. 9

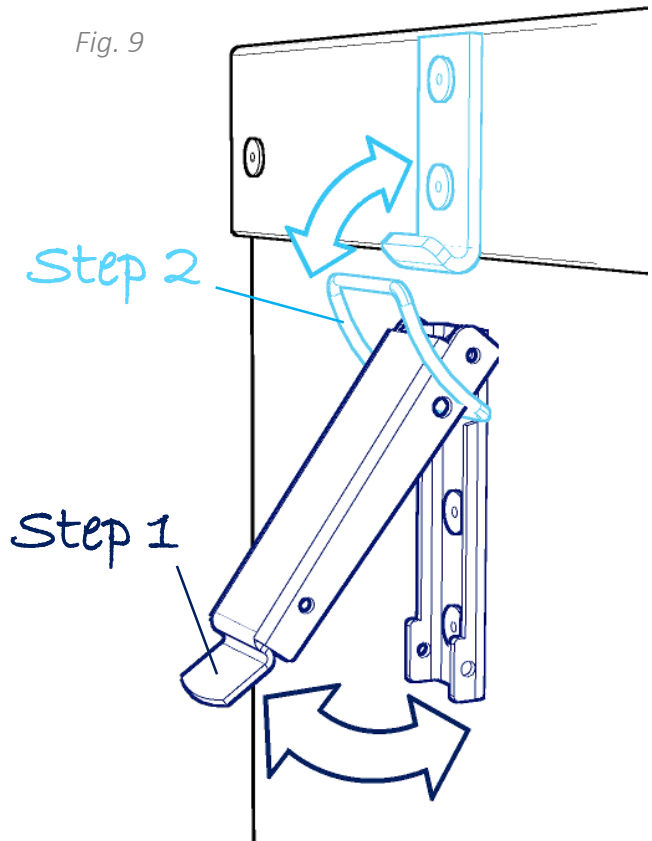
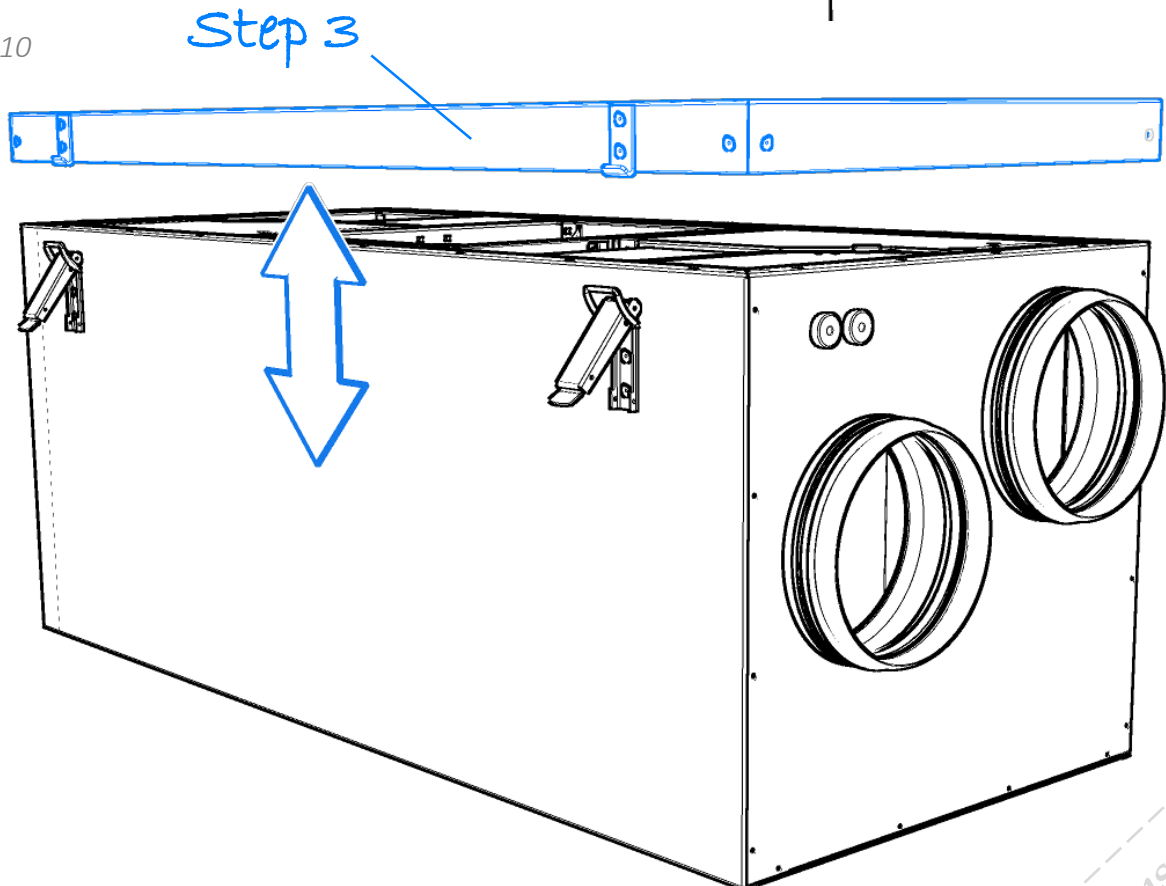
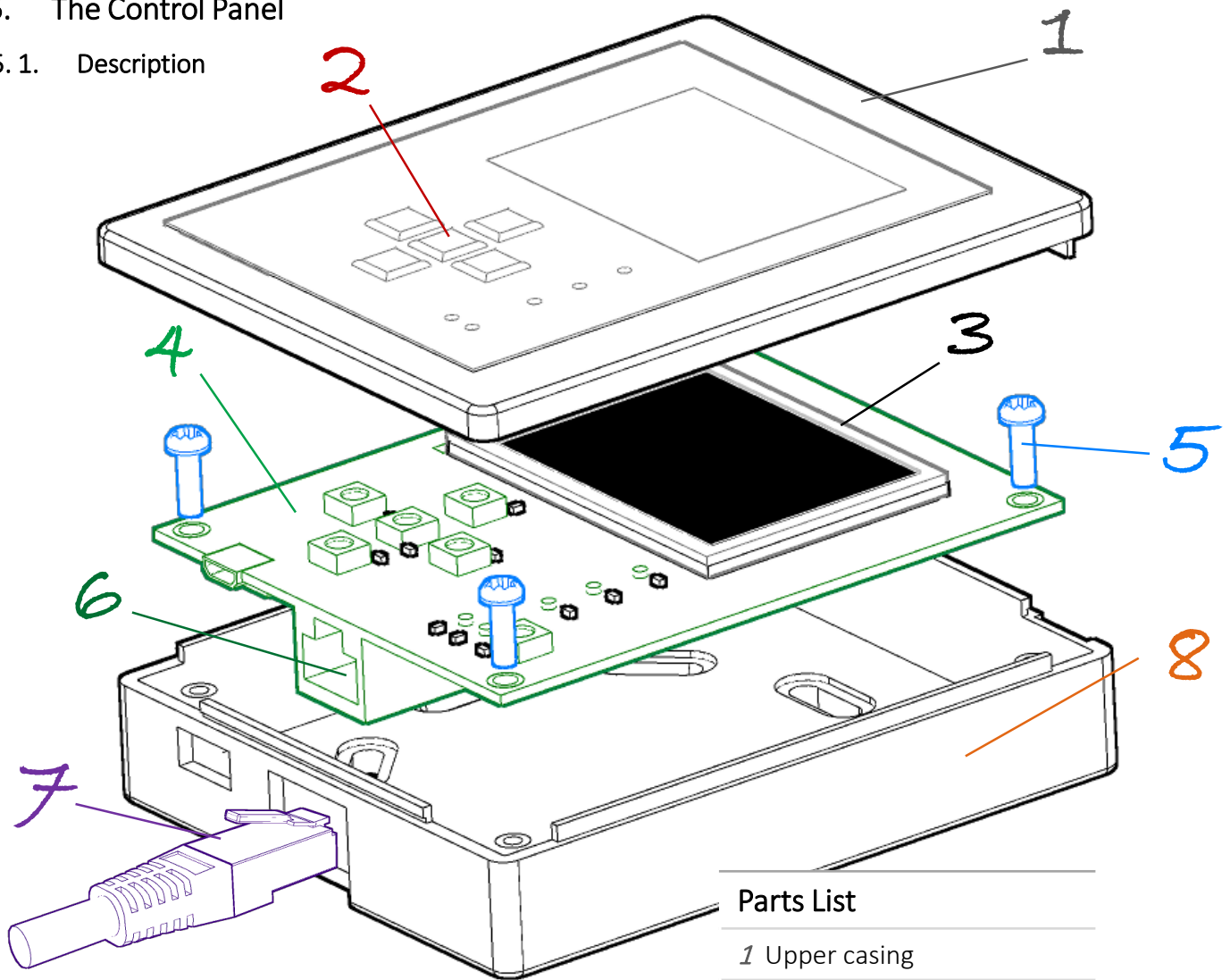

Fig. 10



5. The Control Panel

5.1. Description



Parts List

- 1 Upper casing
- 2 Address panel
- 3 Screen
- 4 Motherboard
- 5 Screws
- 6 Control panel's socket
- 7 Control panel's cord
- 8 Lower casing

5.2. Cable Installation

The unit has a control cord which is connected to the control panel to access the unit. It is important that this plug is easily accessible afterwards for possible faults or when changing the unit.

Cable installation is optional depending on user needs.

The control panel is designed so it can be easily installed on the wall.

The control and power cables measure approximately 2,5 and 2,4 meters.

! WARNING

The control panel must be connected to the unit before the unit is plugged to the power.

! CAUTION

The low voltage cable must be at least 30 cm from power cables.

5.3. Control Panel installation

The device has three main parts: two casings and the motherboard.

To install the control panel, the next steps must be followed. The first step is optional, be used usually to install the lower casing on the wall.

(See fig. 12)

To assemble all three pieces, it is necessary to screw the motherboard to the lower casing first, then attach the upper one by clicking the top of both cases and then slide the lower part towards each other.

Once assembled, connect the cable to the control panel's socket. (See fig. 13 and 14)

Fig. 12

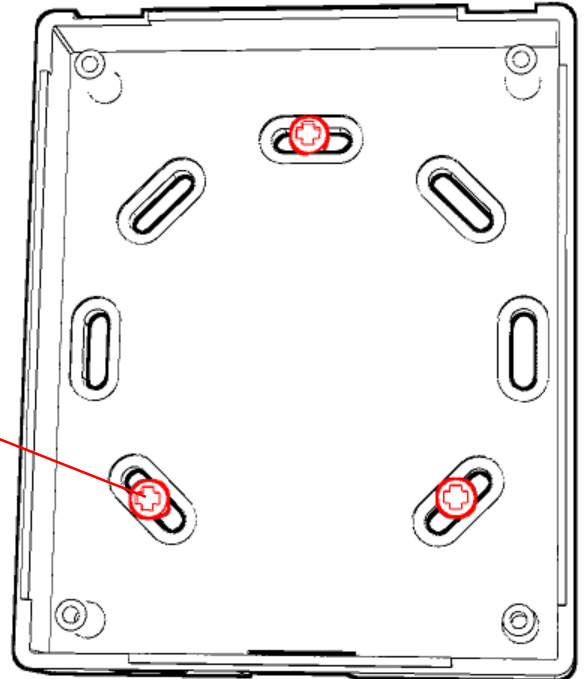
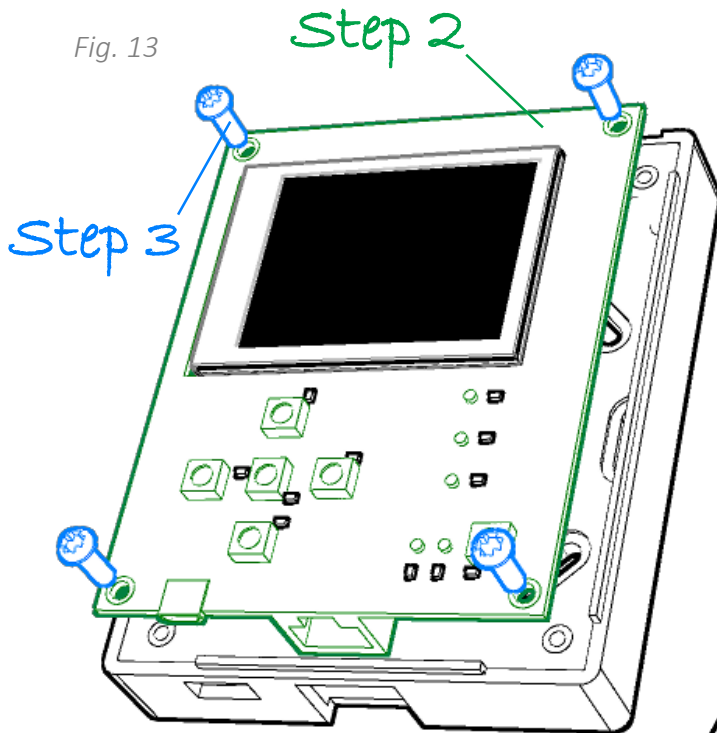
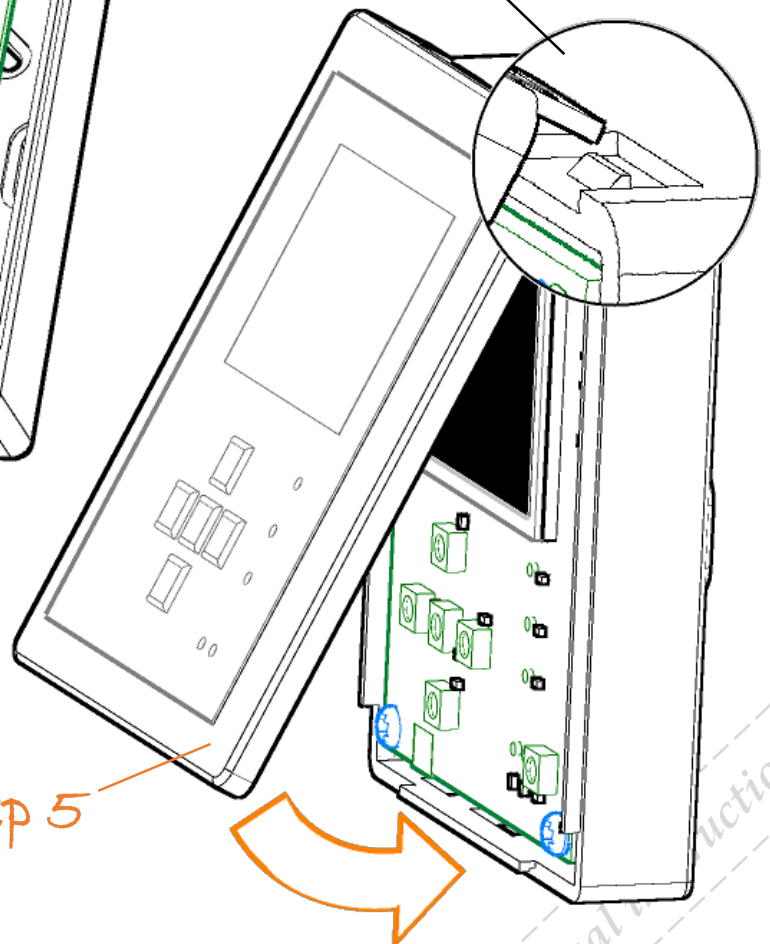

Fig. 13



Step 4

Fig. 14



Step 6

Step 5

5. 4. Unit calibration

- Verify that the control panel has been connected before the unit starts.
- Connect the unit plug.
- The unit will now start.

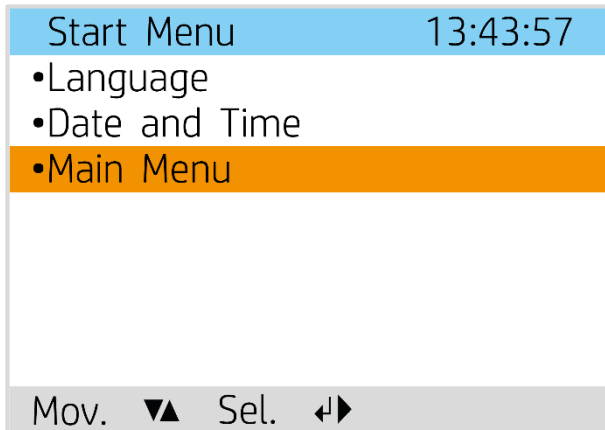

- Once the unit has started, on the control panel go to: *Main Menu / Advanced user / Calibration Test.*

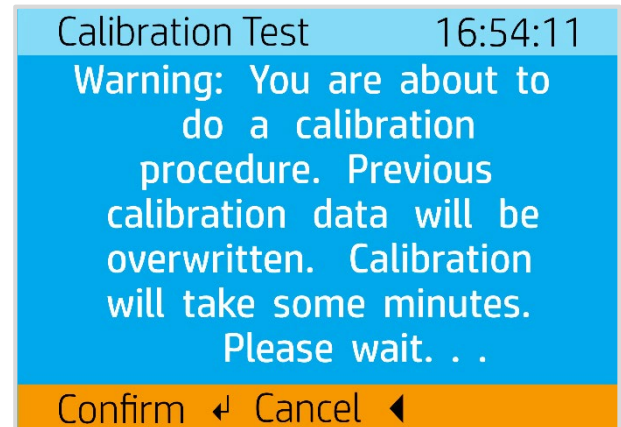
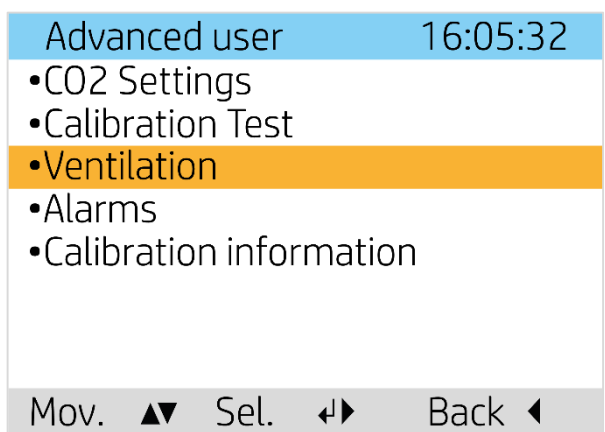
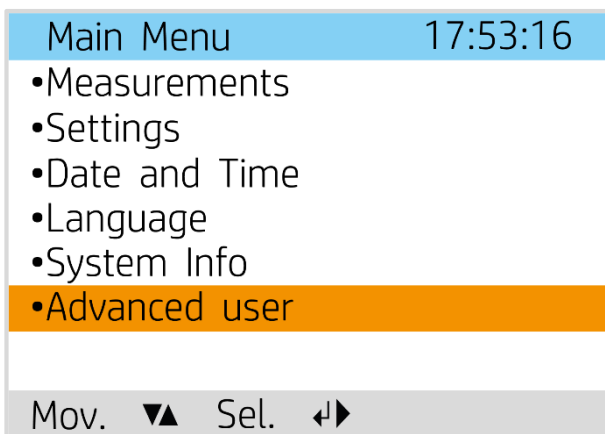

- Press *Confirm and wait* for the calibration test to finish, it will take about 10 minutes.

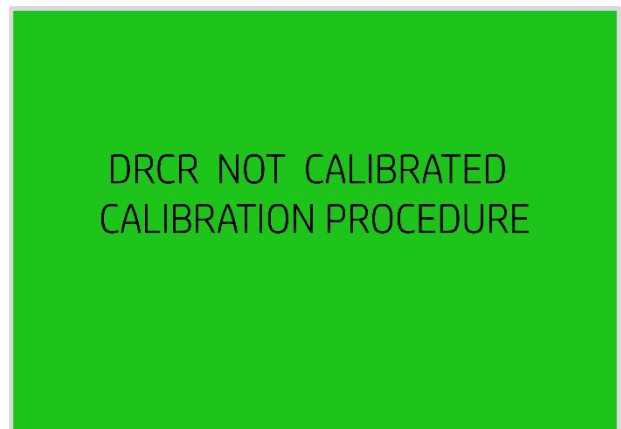

- When finished, the calibration test will return to the Advanced user menu automatically. Then the unit will be installed correctly.

! CAUTION

*The unit **MUST** be calibrated before it is used for the first time and after every filter change. This should be done as instructed in the chapter 11.*

Original instructions

6. Unit maintenance

6.1. Thermostat reset

The unit uses 2 safety thermostats to control that the temperature of the heating element does not exceed 60 °C, when this happens the thermostats cut off the electrical supply of the heating element, actuating the button on the thermostats.

The unit will not operate again until those buttons are pressed manually. (See Fig. 16)

To access the thermostats unscrew and remove the covers of the unit, the electronics and the fan. (See Fig. 15)

Fig. 15

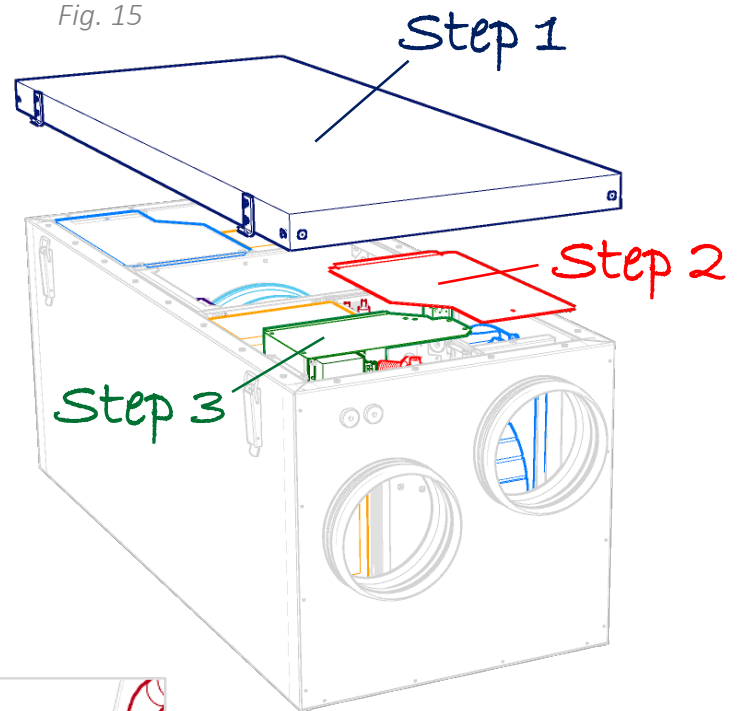
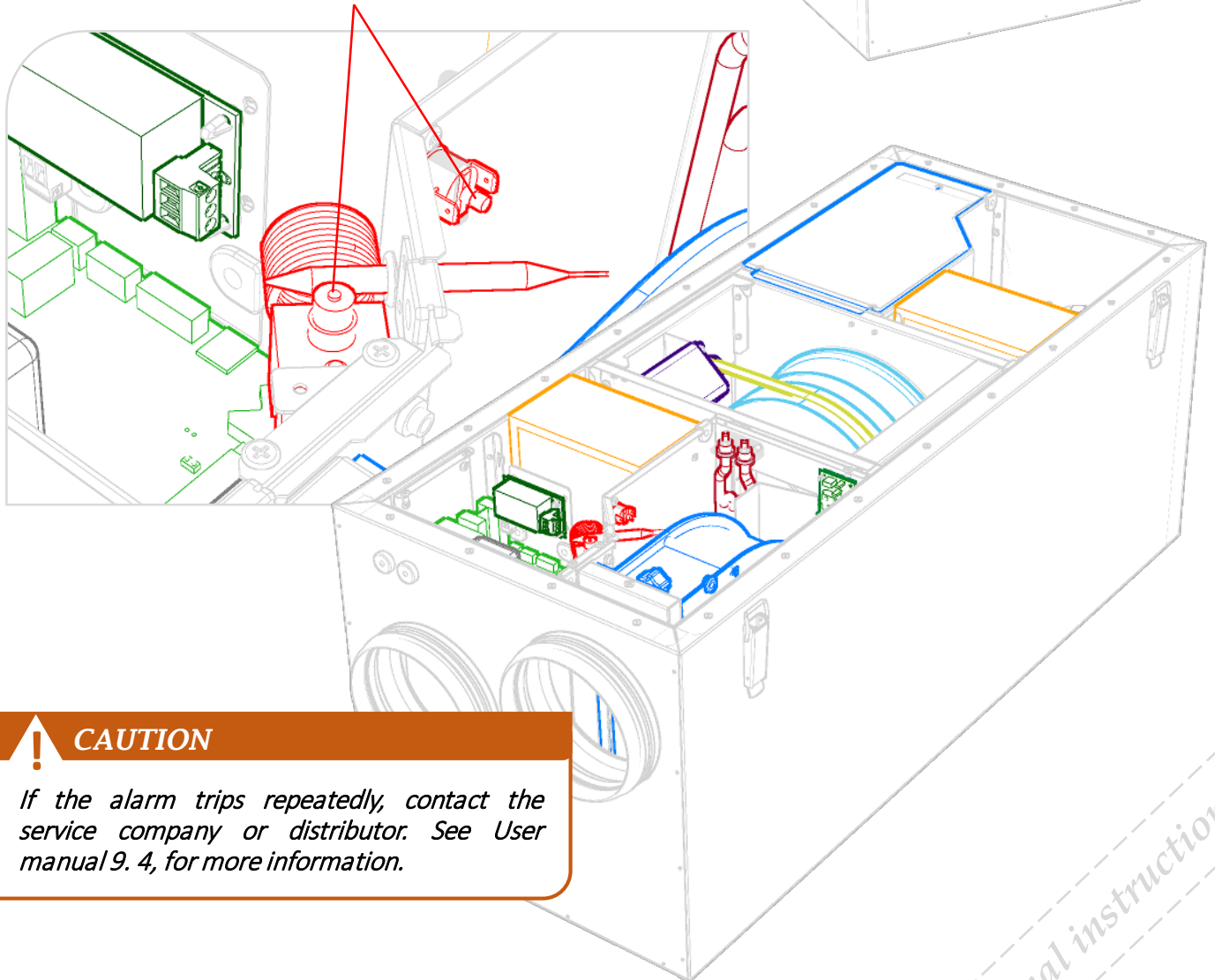

Fig. 16

Thermostat button



CAUTION

If the alarm trips repeatedly, contact the service company or distributor. See User manual 9.4, for more information.

6. 2. Changing the filters

! WARNING

Before opening the door, switch off or unplug the unit. Once the door is removed, wait 5 minutes for the heating element to cool down to touch the unit safely.

The filters have a limited shelf life, and to preserve a healthy indoor air quality it is important to change them when they are dirty.

Dirty filters can, among other things, lead to:

- Reduced efficiency of the unit
- The unit becoming dirty
- Humidity damage to the house
- Reduced indoor air quality

To renew the filters:

1. Pull the filter out (see Fig.17).
2. Put a new filter in.

! CAUTION

Make sure that the filter's outer edge to push it in. A damaged filter reduces the unit's effect and the air purity.

Fig. 17

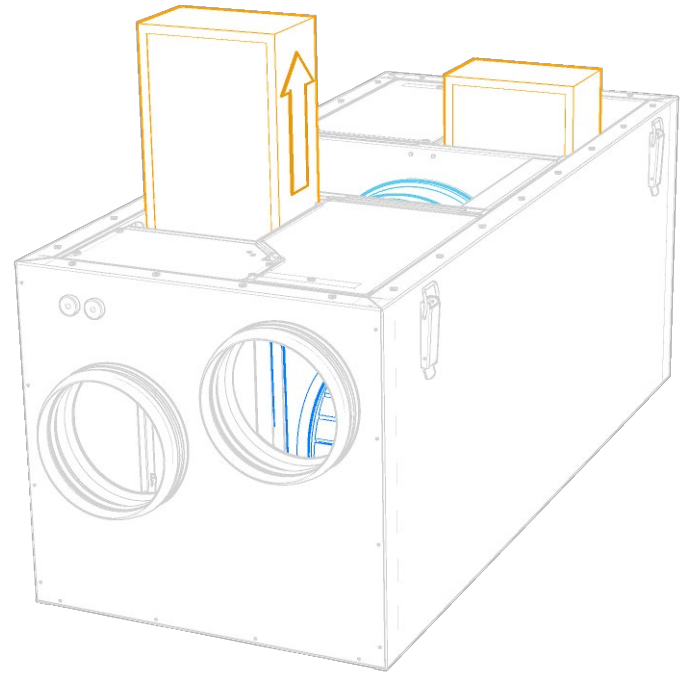

When changing the filter, check the whole unit is working normally.

Use the following checklist:

- Check that the rotor is rotating. turn the rotor in the direction of rotation as shown on the rotor cassette (see Fig. 18).
- If necessary, clean the rotor (see chapter 8.4).
- Check the fans are clean (see chapter 8.2).

Fig. 18

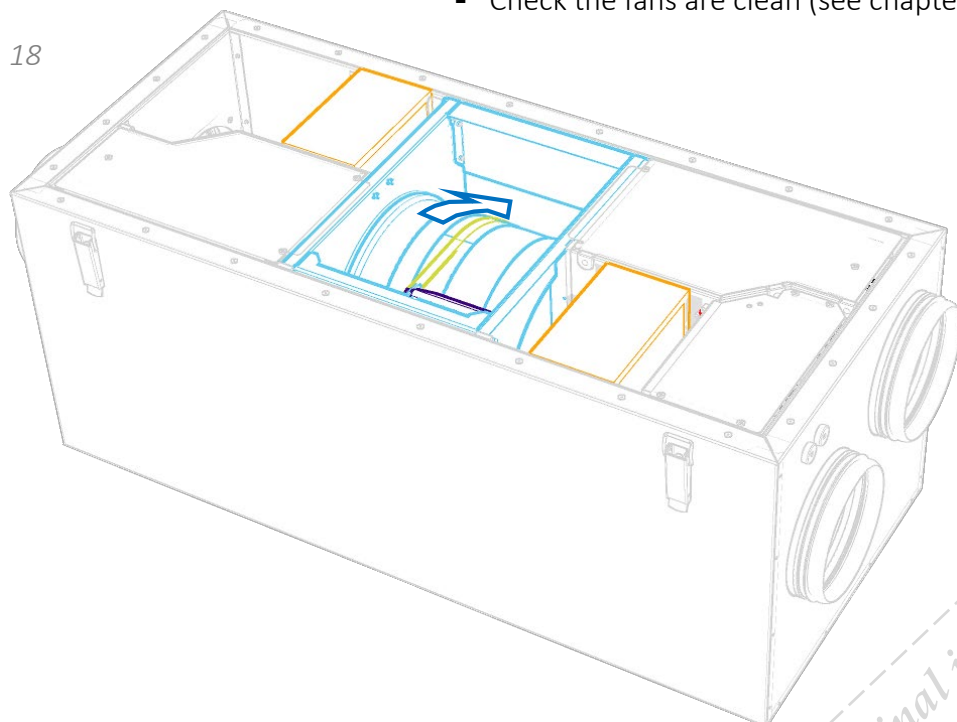

Original instructions

6.3. Cleaning the fans

Fans must be cleaned at least once a year. Clean the fan blades with a grease solvent on a cloth (e.g. methylated alcohols) and compressed air if possible.

! WARNING
Do not use water to clean the unit.

To take out the fans:

1. Pull out the electric quick-release contacts for the fan (see Fig. 19).
2. Take the safety screw off and pull the fan housing out of the unit, the two fans are released with the same process (see Fig. 20). Take care not to damage the seal when you pull the fan housing out.

To put the fan back, follow points 1 and 2 in reverse order.

Fig. 19

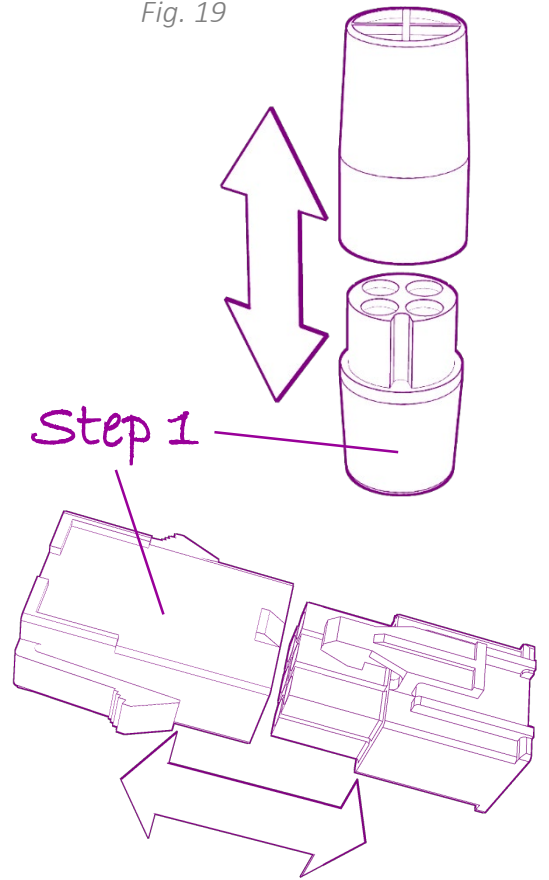
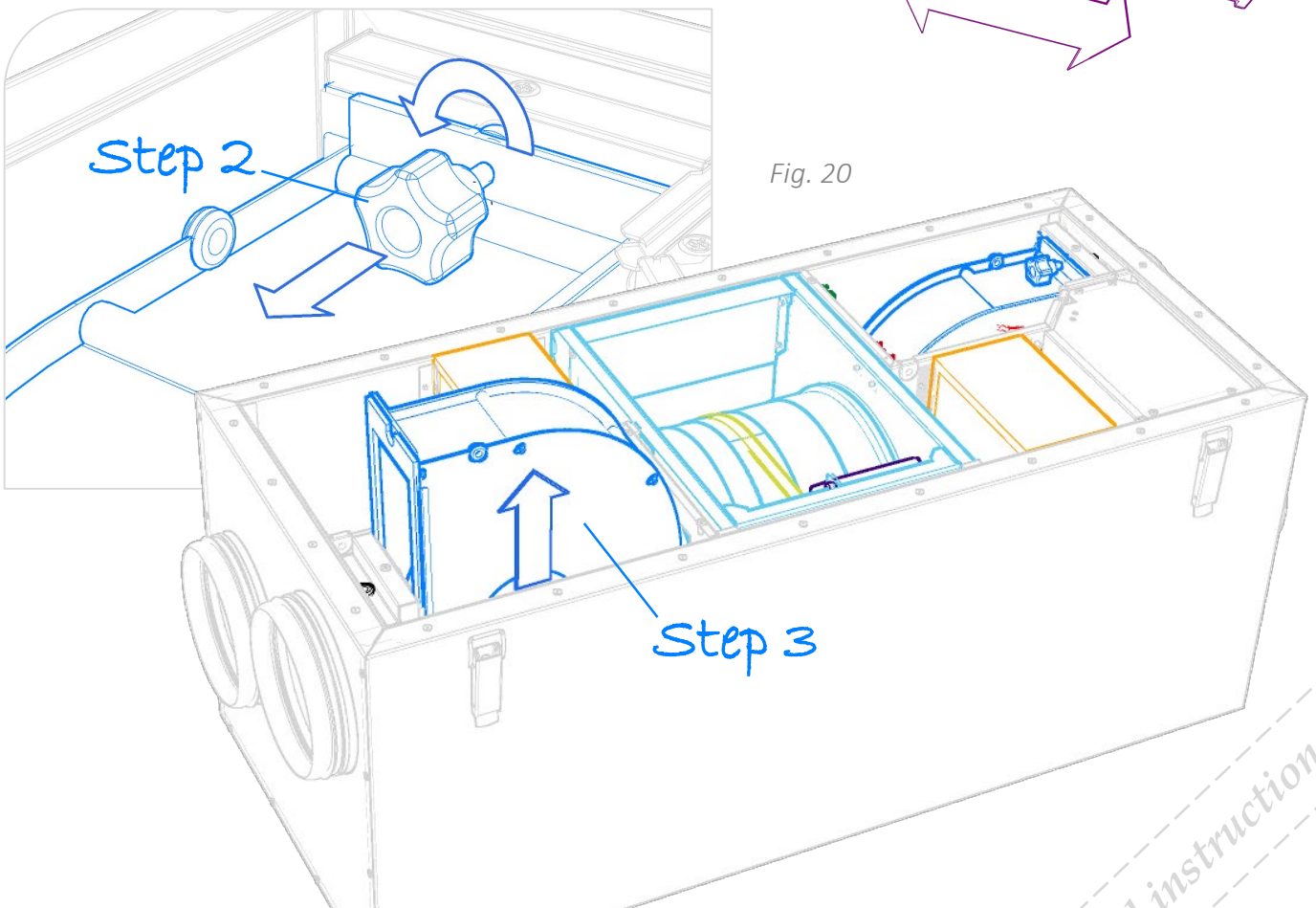

Fig. 20



Original instructions

6.4. Cleaning the rotor

As the unit has high permeability filters installed, it is not usually necessary to clean the rotor. If, for various reasons, should still be necessary, dust can be removed with a soft brush. Further cleaning is possible by removing the rotor, spraying it with a grease solvent and then blowing it clean from the opposite side. Distance approximately 60 mm, and maximum pressure 8 bar. Ensure that the motor is not exposed to water during cleaning. Ensure that all seals around the rotor are intact and tight. Ensure that there is no damage to the rotor belt, and the rotor operates freely.

To access the rotor follow these steps:

1. Remove the safety cover of the air exhaust fan.
2. Remove the safety cover of the air supply fan.
3. Undo the screw for the electric cover and take the cover off.
4. Disconnect the rotor's quick-release contact from the power supply by pressing the release down and pulling the contact.
5. Pull the rotor module straight out.

! CAUTION

Do not use abrasive cleaners or scouring powder, as such products can damage the surfaces. Cleaners containing ammonia or citrus must not be used. Products that give stainless steel an anti-fingerprint coating must not be used either.

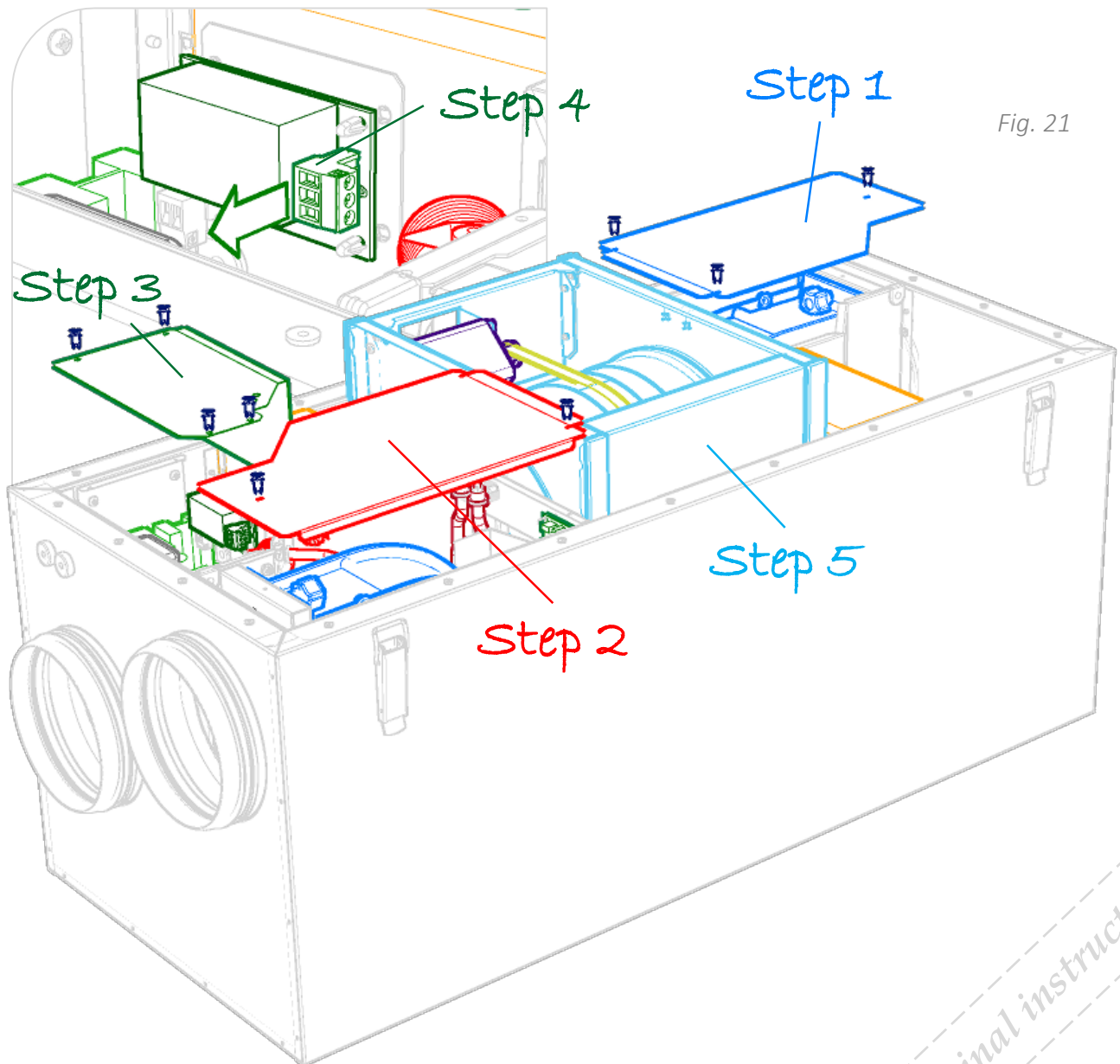

Fig. 21

6.5. Changing the brush strips

The brush strips become worn over time. If they are not tightly fitting with the rotor, it may be necessary to change them in order to avoid airflow loss.

! WARNING

Unplug the device before manipulating.

Proceed as follows:

1. Remove the screws in the sides of the steel profile (see Fig. 22-1).
2. Pull the brush strips out (see Fig. 22-2), to replace them with new ones.

6.6. External cleaning

Many kitchen surface cleaners contain chemicals that may damage the product's plastic components. Therefore, use a soft cloth moistened with warm water and a neutral detergent to clean the outside of the product.

! CAUTION

Do not use abrasive cleaners or scouring powder, as such products can damage the surfaces. Cleaners containing ammonia or citrus must not be used. products that give stainless steel an anti-fingerprint coating must not be used either.

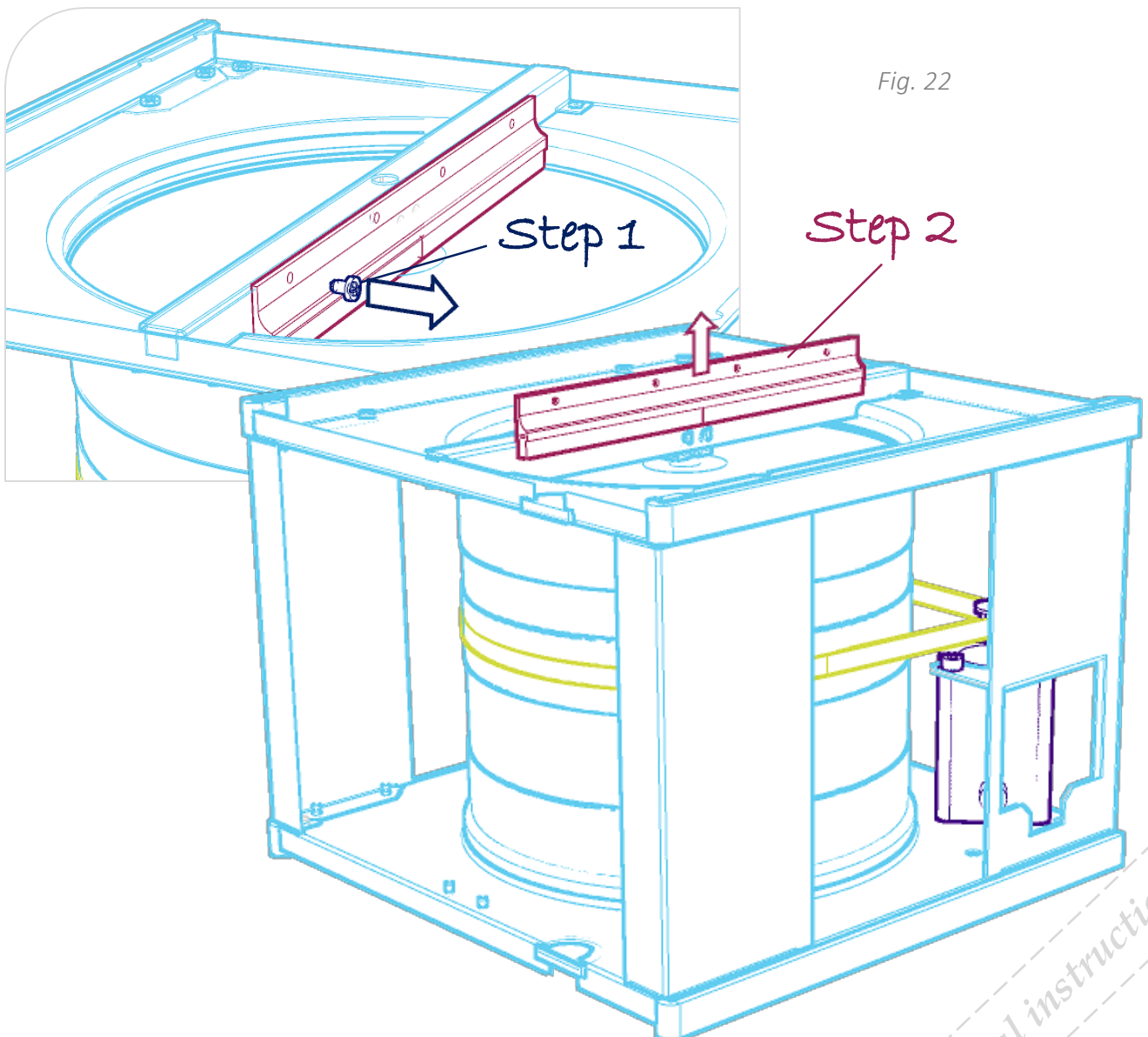

Fig. 22

7. Overview MK control panel

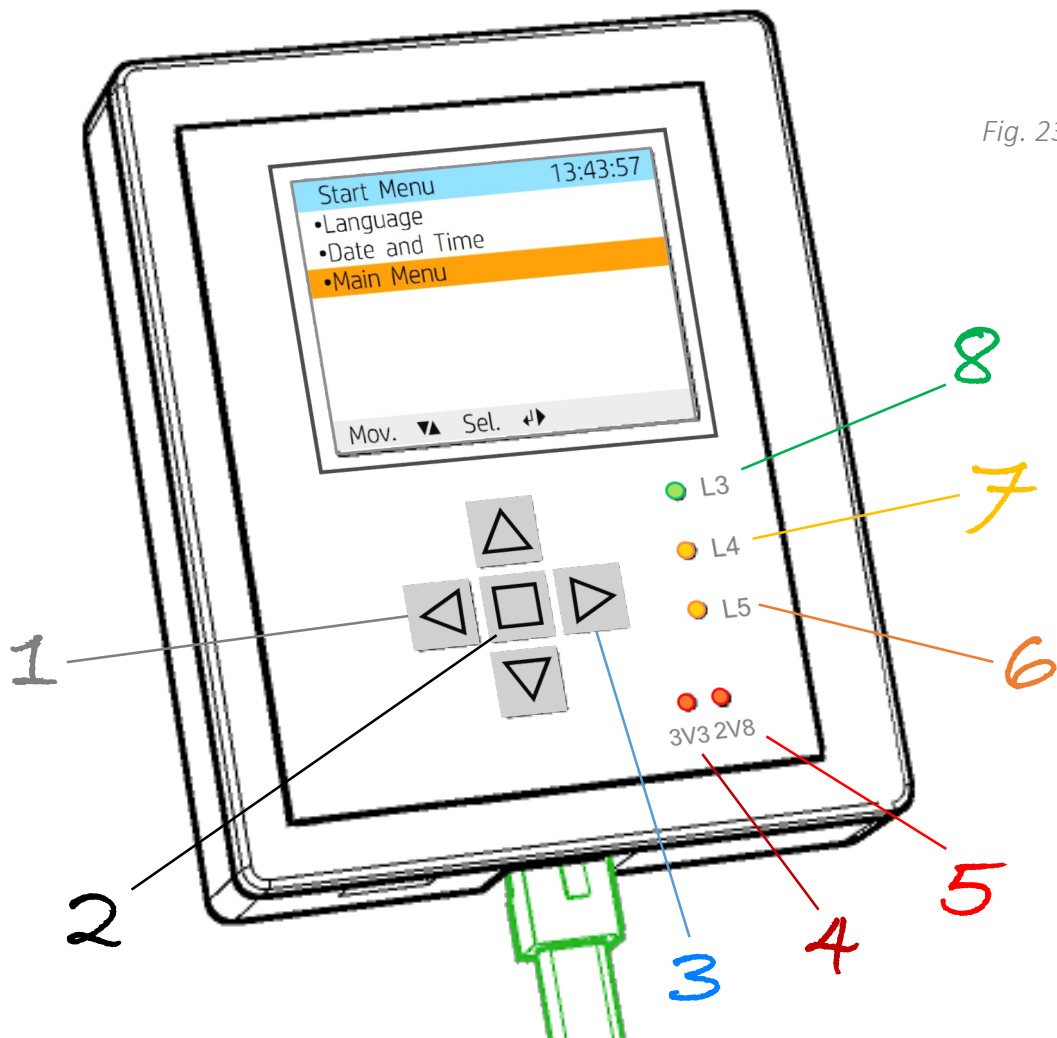

Fig. 23

Navigation parts list	
1	Address panel / BACK
2	CONFIRMATION / ENTER
3	Address panel / INTRO
4	Power supply 3,3 Volts (Red light)
5	Power supply 2,8 Volts (Red light)
6	Alarm (Soft) (Orange light)
7	Alarm (Hard) (Orange light)
8	Start & Operation OK (Green light)

7.1. Description

The control unit consists of a coloured display, pressure switches and indicators (LEDs). The address panel is a membrane keyboard used for adjusting all different functions from the ventilation unit. The control communicates with the ventilation unit through a low-voltage cable.

8. Overview of software

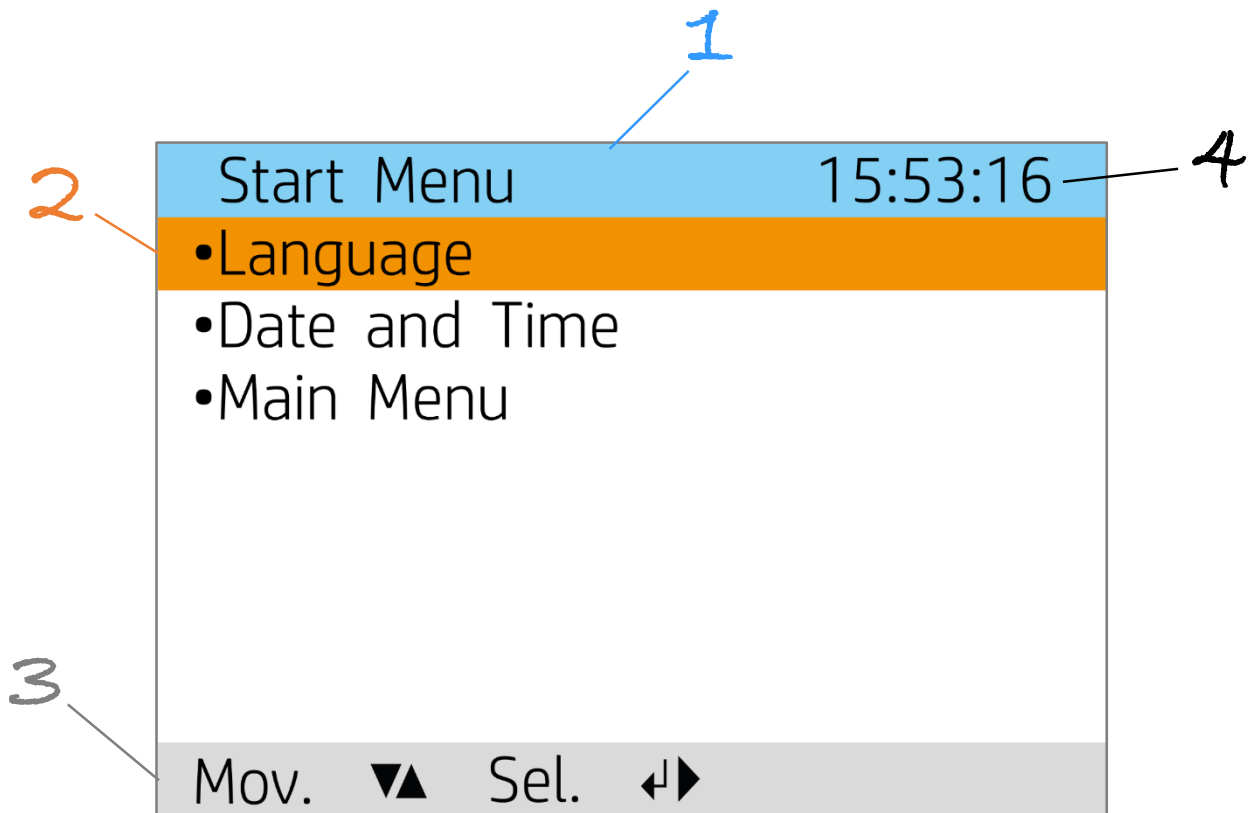

Screen indicators list	
1	Menu name and position (Blue highlight)
2	Navigation selector (Orange highlight)
3	Navigation options (Grey highlight)
4	Time

8.1. Description

The software that manages the operation of the unit automatically. This receives reading data from sensors constantly. This means that the software measures at every moment the temperature of the four channels of the unit, the level of CO₂, relative humidity of the house or premises and the difference in pressure at the entrance and exit of the air during all the day. Depending on the readings it receives from the sensors, it corrects the flow of the fans, the speed of the rotor and the temperature of the electric resistance. Thanks to software, we are able to control at all times the quality of the air that is breathed in the environment and the thermal efficiency of the rotor, which allows us to considerably reduce heating costs with very low electrical consumption.

In addition allows you to change your configuration to the needs of each user without losing intelligent control.

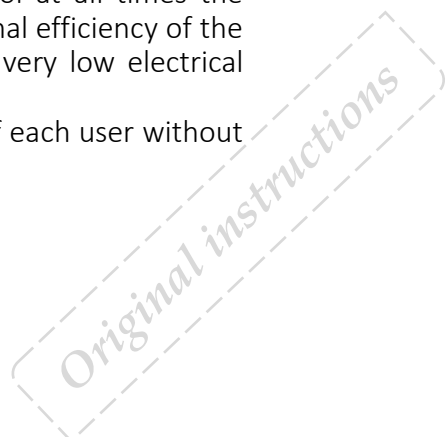

8.2. Control panel navigation

The address panel is used to navigate through the menu lines. The cursor is illustrated by an orange highlight. To make a selection on the current menu, place the orange line on the chosen option then press button INTRO or RIGHT to confirm.

If you select a function that has numerical values, the current value is displayed with two directions icon (UP and DOWN). the value is changed with buttons UP and DOWN and then confirmed by pressing button INTRO.

The cursor can be moved to the right and left, until all settings have been changed. Once finished, confirm to exit the menu. If you want to cancel a function or return to the previous menu screen, use button BACK or LEFT.

8.3. Standby mode

The panel will go into Standby if it is not used for a while. The display will be off but it will light up again if any of the Buttons is pressed.

Fig. 24

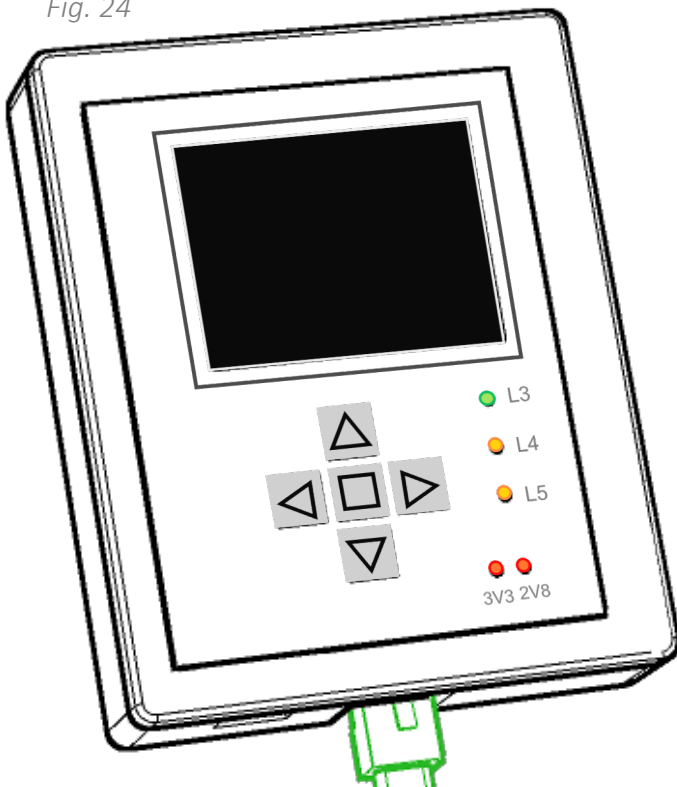

9. Start Menu

When the system is started, the first menu is opened, "Start Menu".

In this menu there are three options:

- **Language**, starts by default in English.
- **Date and Time**, it will only be necessary to configure it the first time you start the unit.
- **Main Menu**, once you access this menu, does not allow you to go back. But the date and time can be modified in the main menu.

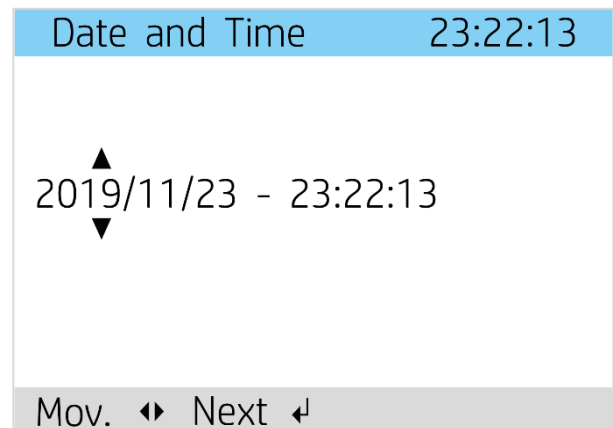
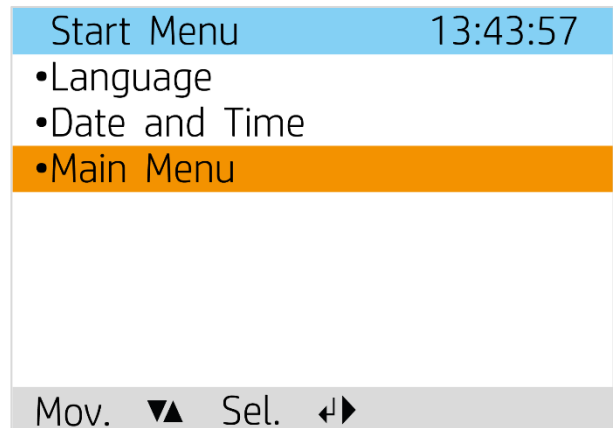

Original instructions

10. Main Menu

This menu is used to control the status and operation of the unit.

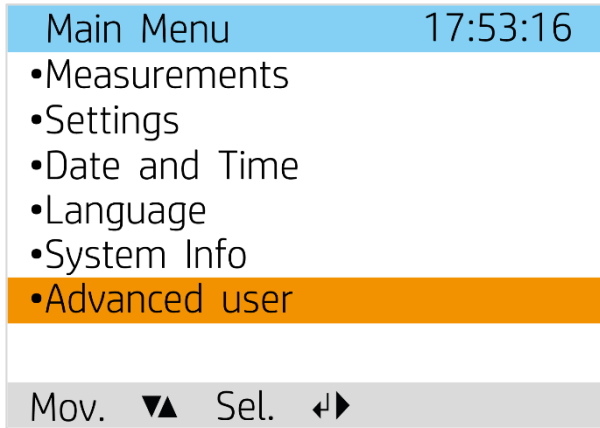

10.1. Measurements

Displays current temperature values, CO2 levels, relative humidity, airflow and filter status.

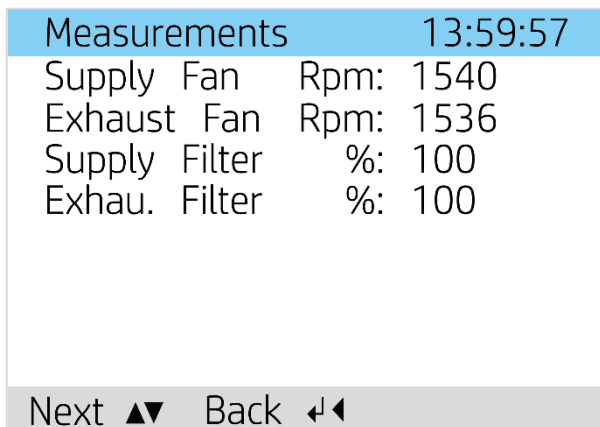
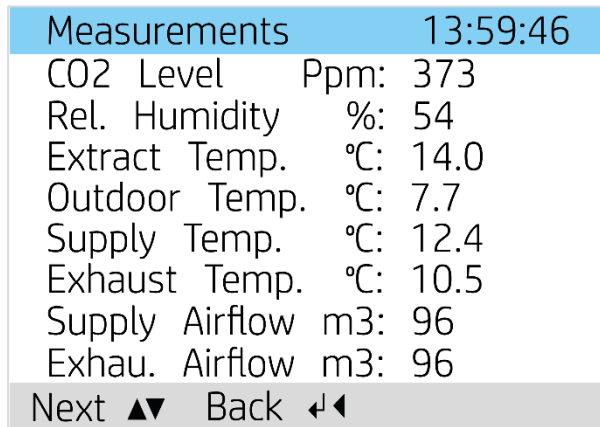

10.2. Settings

It allows configuring the unit's operation in the following modes:

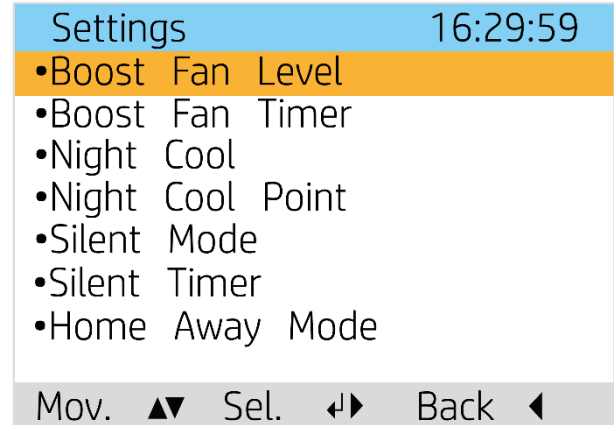

- **Boost Fan Level**, used to increase the airflow of the unit.

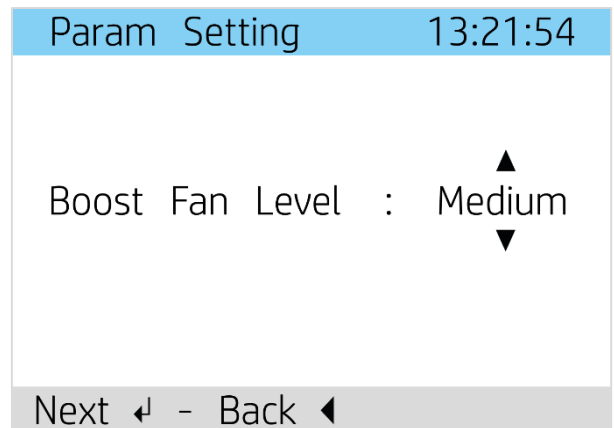

This function allows you to choose between three levels of airflow.

Minimum It must not be used when the house is occupied or during the first two years after a new house is built.

Medium Used under normal conditions. On this settings the air supply must be adjusted according to standard regulations.

Maximum Used if there is a need for increased air supply on account of higher occupancy or a raised humidity level, such as shower or bath times, or when clothes are being dried. This setting is normally used for limited periods.

- **Boost Fan Timer**, the boost fan timer manages the time period that activates the Boost Fan Level with a limited period of 120 minutes maximum. Once the time is due, it will return back to its originally set airflow. This function is ideal during showering, for example, when there is a greater need for extraction for limited periods. When the function is active, the countdown is on display.

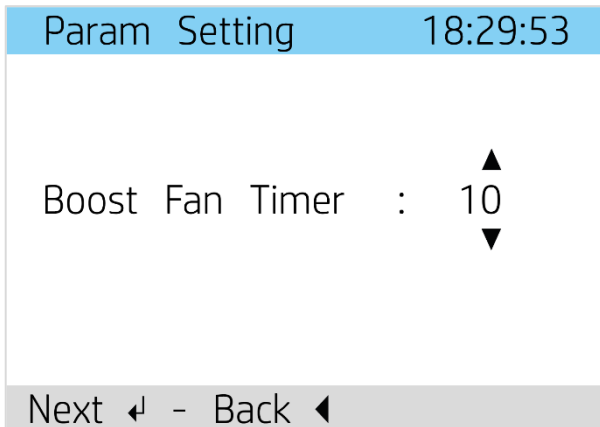

- **Night Cool**, the night cool is a function that allows to cool down the inside when the temperature outside is colder during night time. This options is used during warmer seasons, at night, when there is a chance to cool down the house.

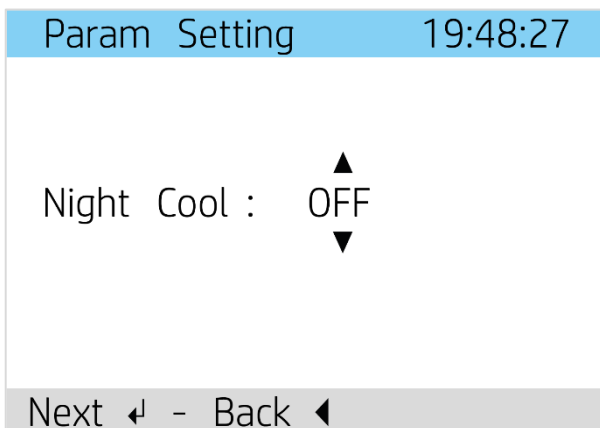

- **Night Cool Point**, this feature is used to define the temperature desired by the user. It can be set from 16°C to 26°C which will regulate the incoming air temperature.

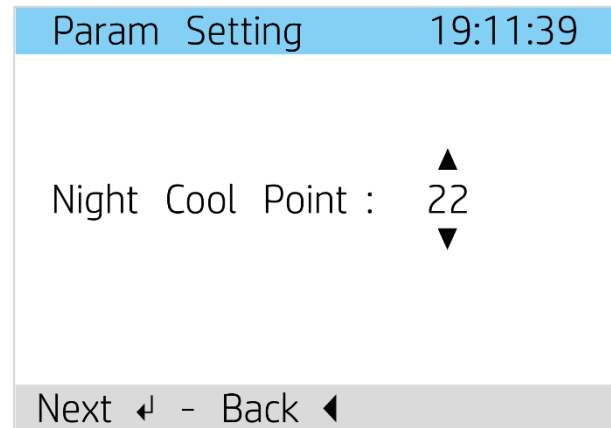

Once you set the preferred temperature, the night cool will be on until the temperature is lower than what has been set, or the outdoor temperature is higher than the indoors, this way it is automated throughout the entire warm season.

- **Silent Mode**, the silent mode is used to reduce ventilation noise, putting fans at minimum power. When this option is activated the unit reduces the speed of the fans to a minimum. This function is only disabled manually or by programming the silent timer.

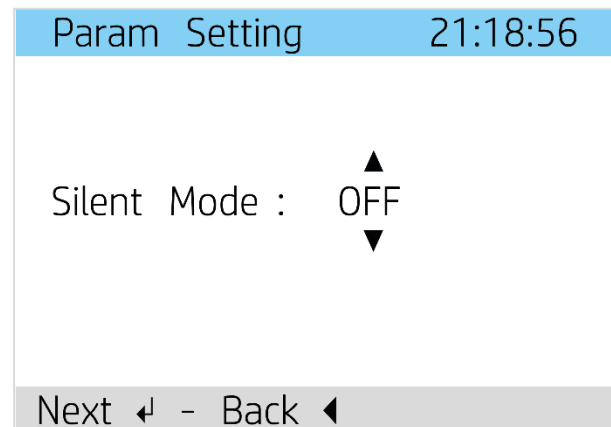

This function is usually used during the night, so that ventilation does not disturb users when they sleep.

- **Silent Timer**, this feature is used to program the duration time of silent mode.

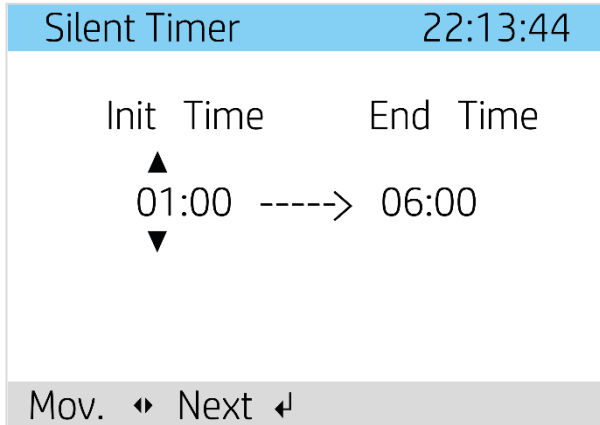

- **Home Away Mode**, on this function the unit turns off, and every 24 hours it turns on for 15 minutes to move the rotor and change the air. The home away mode does not have automatic exit, because it is usually used for long absences, for example, when users go on vacation to another country for a long period, and they need to renew the air to avoid humidity problems in the house.

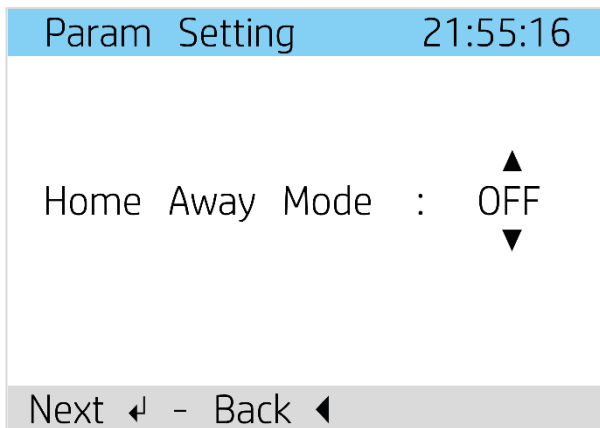

10.3. Date and Time

This function is also implemented in this menu, because the software does not do the seasonal time change automatically.

10.4. Language

This option is also implemented in this menu, because it is not possible to return to the start menu from the main menu, in case the user needs to change the language .

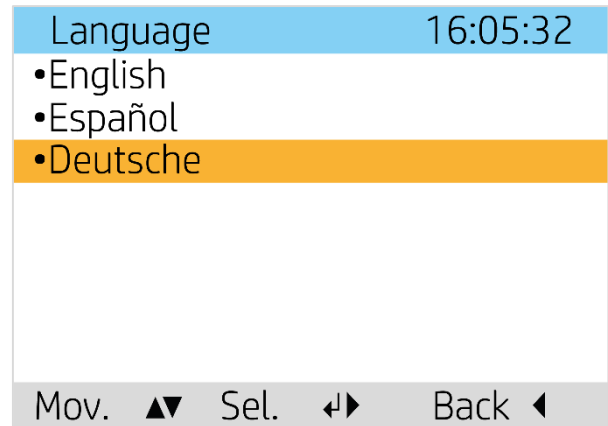

10.5. System Info

This option contains the information about the version of the software that has the unit installed.

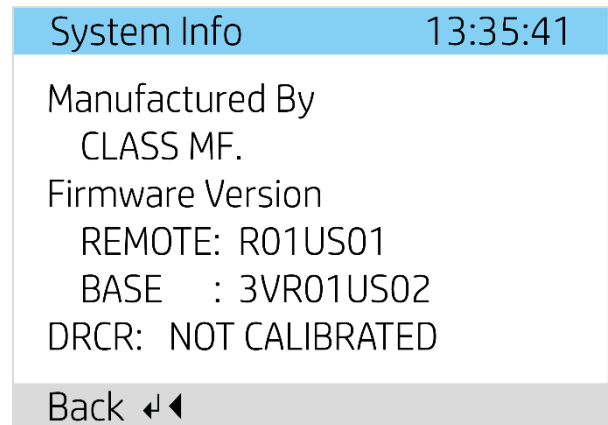

The date and time that this option shows refer to the last software update made.

11. Advanced User Menu

This menu is used for advanced settings and trouble diagnosis.

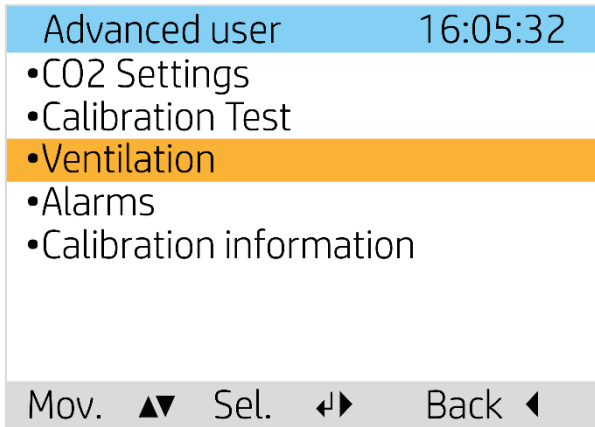

11.1. CO2 Settings

This function is used to adjust the minimum and maximum values of CO2. Once configured, the unit will automatically manage the CO2 levels.

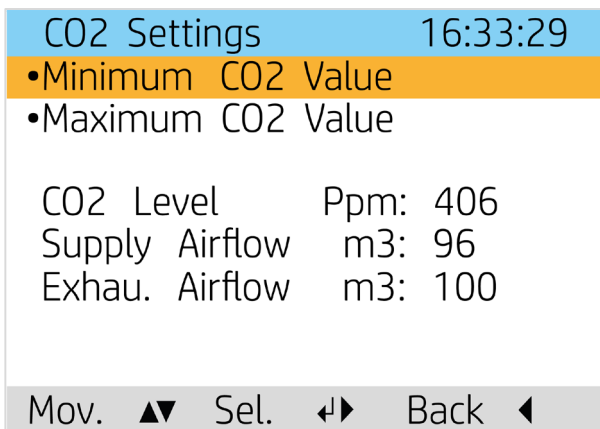

In addition, the menu shows the current measurements of CO2 and air flow. It comes with a default range from 600-1000 ppm. Because it is the optimum range of air quality.

11.2. Calibration Test

This function is the process to optimize the unit to the characteristics of the house. When the calibration test is performed, the unit detects the status of the filters to optimize the airflow to the user's needs.

This process is done automatically every 15 days. This way we ensure the correct operation of the unit.

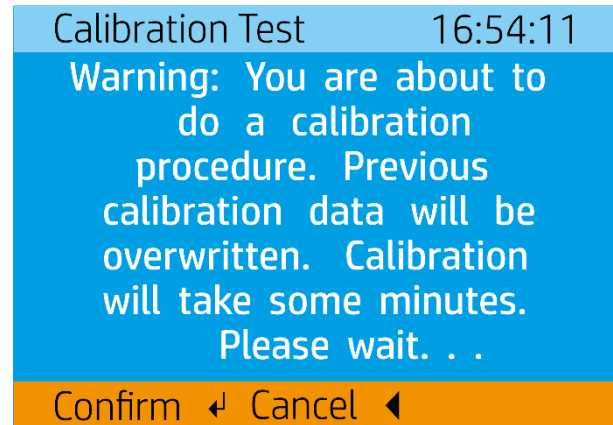

The calibration test must be done before it is used for the first time and after every filter change.

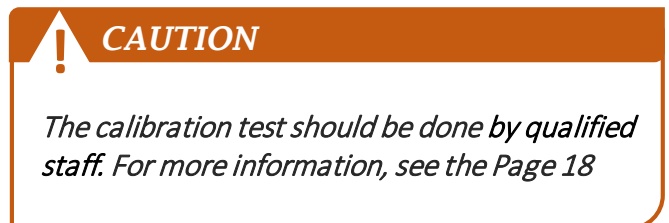

11.3. Ventilation

In this function, you can regulate the airflow to a desired level. The ventilation regulates the fan speed from 10m3/h to its maximum (depending on the device's capacity).

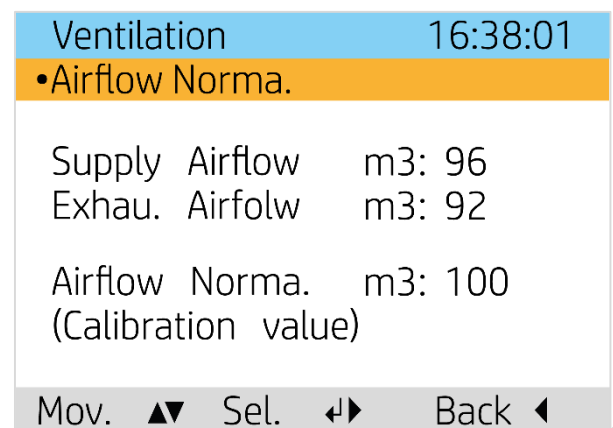

In "Airflow Norma." We set the airflow to which the unit adjusts automatically.

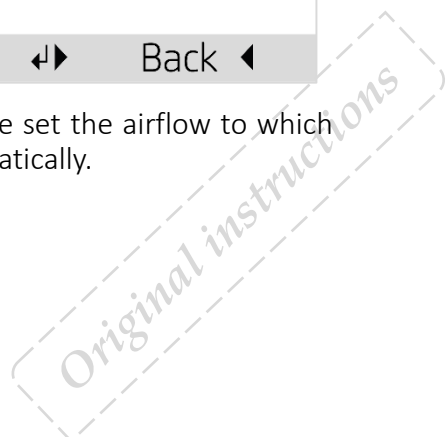

Even though the settings go from 10 to 500 the maximum level will be adapted to the device features.

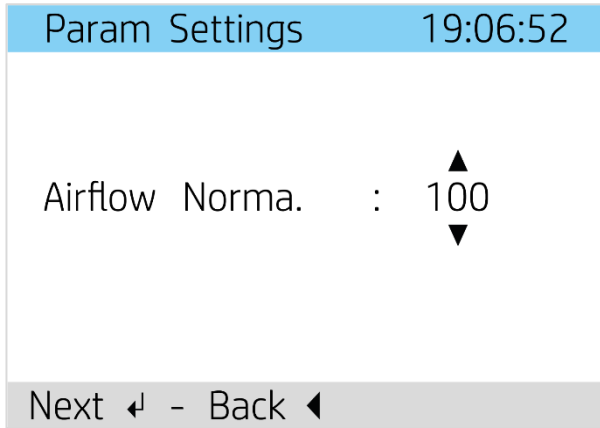

11.4. Alarms

This function is used for diagnosing and repairing problems with the unit. It is usually used when the filters are dirty. The unit detects that the filter needs to be changed, turning on the filter alarm to be replaced.

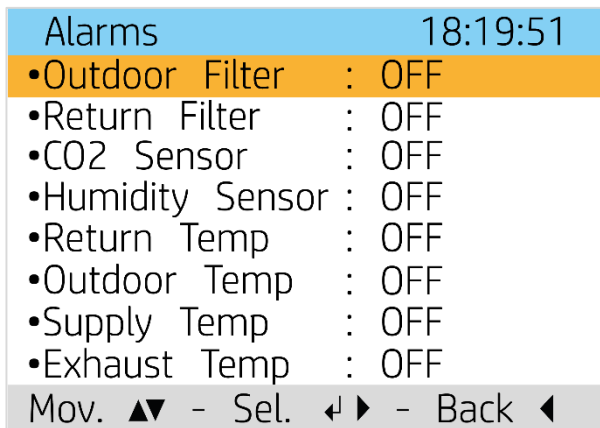

When an error occurs in the unit, the indicators L4 and L5 will illuminate on the control panel and the display will indicate that an alarm has been activated with a warning symbol and a buzzer.



The signal given by the indicators L4 and L5 depends on the issue detected.

When the signal is given, the LED blinks for 5 seconds, and then stays on.

The indications are divided in two types:

Soft (L4 Light on), It means there is a problem going on that doesn't require the unit to stop.

Hard (L4 and L5 Lights on), It means there is a problem that requires to be solved.

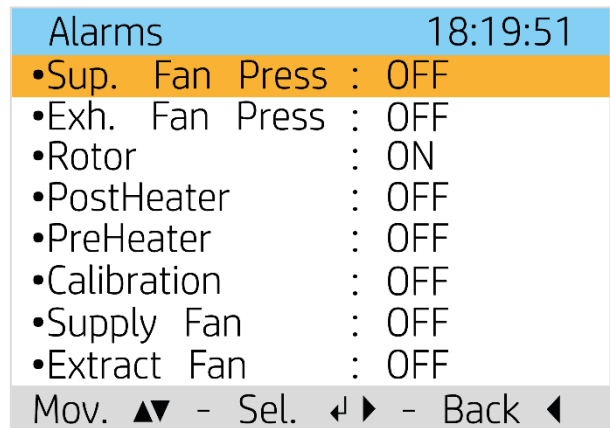

When an Alarm is activated, the software will allow deactivated it asking if this problem has been fixed.

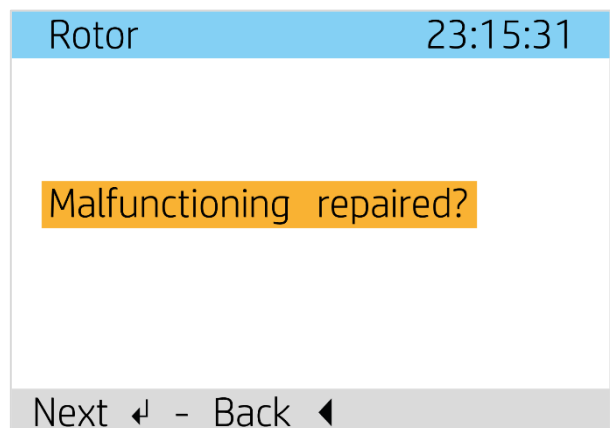

Once the alarm repair has been confirmed, if the issue has not been repaired correctly, the alarm it will be activated again.

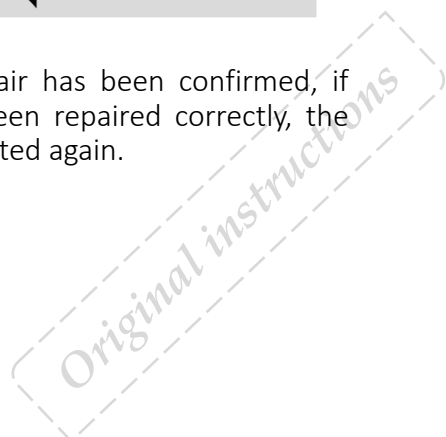

11.5. Menu Tree

Fig. 25

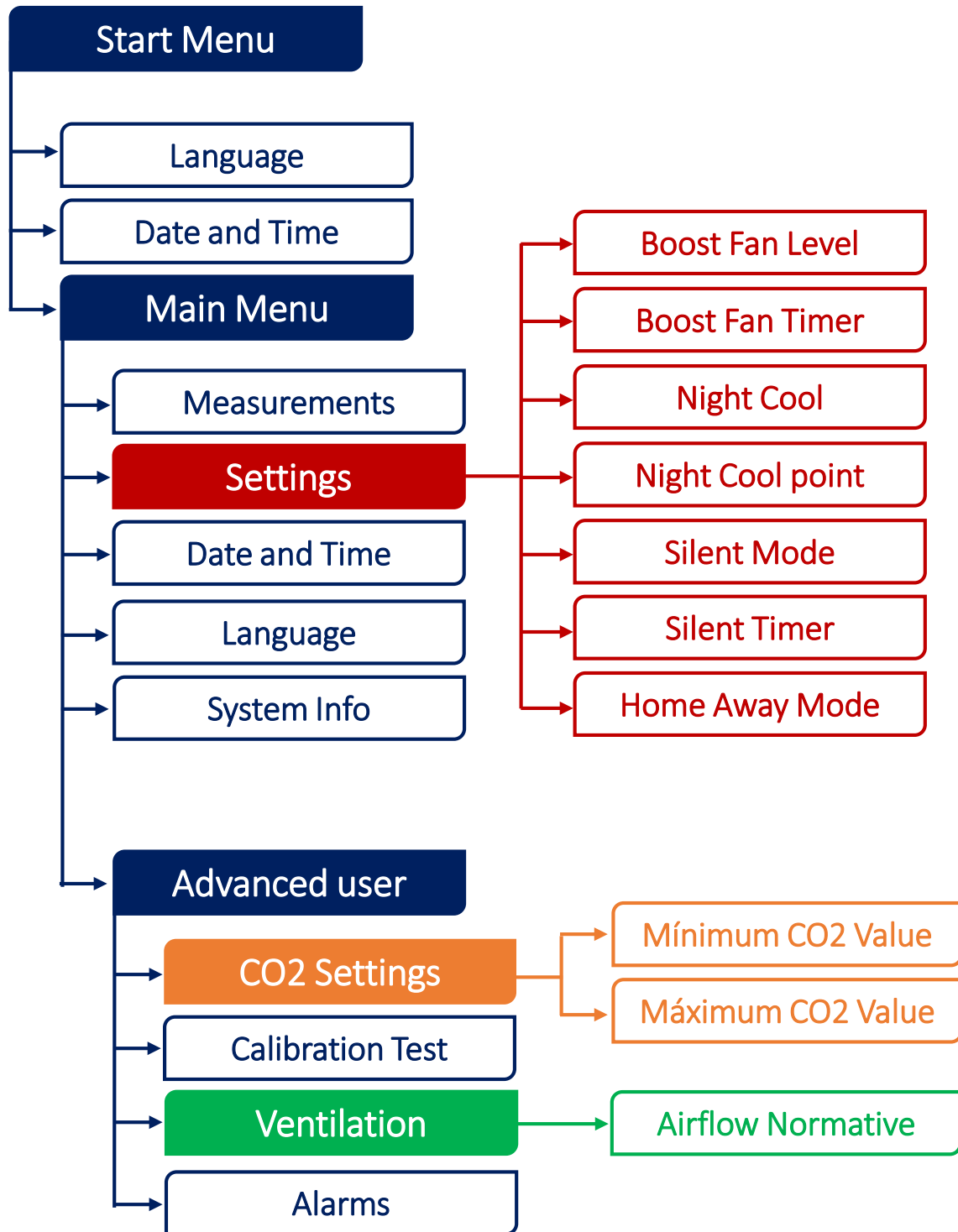

12. Cleaning and maintenance

Component	Action	Interval
Filter	Filters must be changed at least once a year. It is best to change them twice a year, before and after the pollen season. check that the filter seal is completely tight.	6-12 months
Fans	Fans must be cleaned at least once a year to maintain fan efficiency.	12 months
Rotary wheel-type heat exchanger	Make sure the surfaces are clean. Check the sealing strips are facing towards the rotary wheel-type heat exchanger. check that the rotor belt is intact and not too slack.	12 months
Kitchen hood*	Wash the grease filter. check that the damper is clean and closes fully.	2 weeks
Seals	Check that the seals on the door, under the filters, on the fan modules and on the rotor module are intact.	12 months
Valves	The supply air and extract air valves (for the bathroom, bedroom, laundry room, etc.) must be cleaned at least once a year.	12 months
Air intake	Check that no leaves and other items have caught on the grille. In periods of sea smoke during winter the air intake can freeze up. If necessary it must be scraped clean so that the air can pass through.	12 months
Ducts	Check that the ducts are clean.	10 years
Brush strips	Check the brush strips are intact and sit tightly against the rotor. If they are worn, they must be changed.	3 years
Inside unit	A combination of a very low outside temperature and damp extract air can lead to the formation of ice. Normally this will not be a problem - when normal operating conditions return the ice crystals will be converted to steam and removed from the unit via the exhaust air. In the case of extreme cold over extended periods the unit should be checked for ice.	

*For units with extract air from the kitchen hood connected to the unit.

13. Troubleshooting

Type of alarm	Remedial actions
Outdoor Filter	<ol style="list-style-type: none"> 1. New <i>Outdoor</i> filter needed. 2. Perform <i>Calibration Test</i>. 3. Deactivate the alarm. 4. If the alarm is activated again, contact your support service.
Return Filter	<ol style="list-style-type: none"> 1. New <i>Extract</i> filter needed. 2. Perform <i>Calibration Test</i>. 3. Deactivate the alarm. 4. If the alarm is activated again, contact your support service.
CO2 Sensor	<ol style="list-style-type: none"> 1. Restart power to the unit. 2. Deactivate the alarm. 3. If the alarm is activated again, contact your support service.

Type of alarm	Remedial actions
Humidity Sensor	<ol style="list-style-type: none"> 1. Restart power to the unit. 2. Deactivate the alarm. 3. If the alarm is activated again, contact your support service.
Return Temp. Outdoor Temp. Supply Temp. Exhaust Temp.	<ol style="list-style-type: none"> 1. Check that the temperatures are not at 0 °C. See the remote control. 2. Restart power to the unit. 3. Deactivate the alarm. 4. If the alarm is activated again, contact your support service.
Sup. Fan Press.	<ol style="list-style-type: none"> 1. Restart power to the unit. 2. Deactivate the alarm. 3. If the alarm is activated again, contact your support service.
Exh. Fan Press.	<ol style="list-style-type: none"> 1. Restart power to the unit. 2. Deactivate the alarm. 3. If the alarm is activated again, contact your support service.
Rotor	<ol style="list-style-type: none"> 1. Check that the rotor is rotating. 2. Check that the <i>Outdoor</i> and <i>Supply</i> temperatures are more than 4 degrees apart. See the remote control. 3. Deactivate the alarm. (Use only in Winter, when there is a risk of frostbite) 4. If the alarm is activated again, contact your support service.
PostHeater	<ol style="list-style-type: none"> 1. Check if the safety thermostats have been activated. 2. Deactivate the alarm. 3. If the alarm is activated again, contact your support service.
PreHeater	<ol style="list-style-type: none"> 1. Check if the safety thermostats have been activated. 2. Deactivate the alarm. 3. If the alarm is activated again, contact your support service.
Calibration	<ol style="list-style-type: none"> 1. Check that the remote control is connected correctly. 2. Restart power to the unit. 3. Deactivate the alarm. 4. If the alarm is activated again, contact your support service.
Supply Fan	<ol style="list-style-type: none"> 1. Check that <i>Supply Airflow</i> is not at 0 m³/h. See the remote control. 2. Verify that the <i>Supply Fan</i> is not at 0 RPM. See the remote control. 3. Deactivate the alarm. 4. If the alarm is activated again, contact your support service.
Exhaust Fan	<ol style="list-style-type: none"> 1. Check that <i>Exhaust Airflow</i> is not at 0 m³/h. See the remote control. 2. Verify that the <i>Exhaust Fan</i> is not at 0 RPM. See the remote control. 3. Deactivate the alarm. 4. If the alarm is activated again, contact your support service.

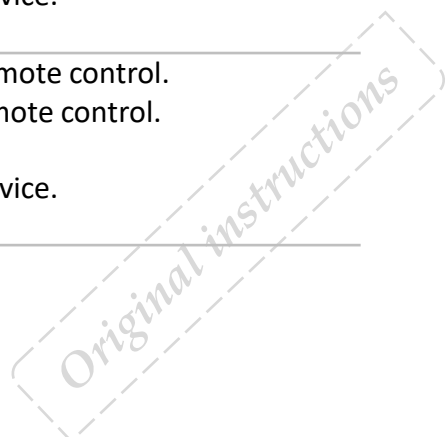



www.classmf.es

EC Declaration of Conformity

We, the undersigned,

Class Manufacturing S.L.

Address: C/ Urano nº 2 - Polígono Industrial nº 2 La Fuensanta
28936 Móstoles (Madrid)

Country: Spain

Declare under our responsibility that the following product:

Heat Recovery Unit - Classphere 200H

Complies with requirements of following European directives:

Directive 2014/35/EU (Safety Standard)

Directive 2014/30/EU (EMC Standard)

And for this the following standards are met:

Safety Standard IEC 60335-2-30 IEC 60335-2-80	IEC 60335-2-30:2009 + A1:2016 IEC 60335-2-80:2015 used in conjunction with IEC 60335-1:2010 + A1:2013 + A2:2016 and EN 60335-2-30:2009 + A11:2012 + A1:2020 EN 60335-2-80:2003 + A1:2004 + A2:2009 used in conjunction with EN 60335-1:2012 + A11:2014 + A13:2017 + A1:2019 + A14:2019 + A2:2019 EN 62233:2008
EMC Standard	EN 55014-1:2017 EN 55014-2:2015 EN 61000-3-2:2018 EN 61000-3-3:2013+AMD1:2017

Place and date of issue

Móstoles August 06, 2020



Pablo Arroyo Bayona
General Manager



Original instructions



The right to give notice of lack of conformity applies to this product in accordance with the existing terms of sale, **provided that the product is correctly used and maintained.** Filters are consumables.

The symbol on the product shows that this product must not be treated as household waste. It must be taken to a reception station for recycling of electrical and electronic equipment.

By ensuring correct disposal of the equipment, you will contribute to preventing negative consequences for the environment and health that incorrect handling may entail. For further information on recycling of this product, please contact your local authority, your refuse collection company or the company from which you purchased it.

Notice of lack of conformity as a result of incorrect or defective installation must be submitted to the installation company responsible. the right to give notice of lack of conformity may lapse if the system is used incorrectly or maintenance is grossly neglected.



EMKA®

EMKA MANUFACTURING, S.L.

C/ Júpiter, 3 - 28936 Móstoles, Madrid - Spain

www.emkamf.es

